

FEIDER

MACHINES



CORDLESS RIDER

FRE7548V

USER GUIDE

CAUTION: Read this manual before using this machine!

CONTENTS

1. INTENDED USE.....	3
2. SAFETY INSTRUCTIONS.....	3
3. ASSEMBLY.....	14
4. FEATURES.....	19
5. USING THE PRODUCT.....	25
6. TRANSPORTING THE PRODUCT.....	29
7. MAINTAINING THE PRODUCT.....	30
8. STORING THE PRODUCT.....	35
9. MAINTENANCE SCHEDULE.....	36
10. TROUBLESHOOTING.....	37
11. DECLARATION OF CONFORMITY.....	39
12. WARRANTY.....	40
13. PRODUCT FAILURE.....	41
14. WARRANTY EXCLUSIONS.....	42

1. INTENDED USE

The ride-on mower is intended for outdoor use only. The product is designed for domestic lawn moving. The cutting blade should rotate approximately parallel to the ground over which it is being wheeled.

All four wheels should touch the ground while mowing. The product is to be used only in domestic application by adults who have received adequate training on the hazards and preventive measures or actions taken while using it.

Do not use the product for any other purpose.

2. SAFETY INSTRUCTIONS

GENERAL SAFETY WARNINGS

 **WARNING: read all safety warnings, instructions, illustrations and specifications provided with this machine.** Failure to follow all instructions listed below may result in electric shock, fire, and/ or serious injury.

Save all warnings and instruction for future reference. The term “machine” in the warnings refers to your mains-operated (corded) product or battery-operated (cordless) product.

1) WORK AREA SAFETY

- **Keep work area clean and well lit.** Cluttered or dark areas invite accidents.
- **Do not operate machine in explosive atmospheres, such as in the presence of flammable liquids, gases or dust.** Machines create sparks which may ignite the dust or fumes.
- **Keep children and bystanders away while operating a machine.** Distractions can cause you to lose control.

2) ELECTRICAL SAFETY

- **Machine plugs must match the outlet. Never modify the plug in any way. Do not use any adapter plugs with earthed (grounded) machine.** Unmodified plugs and matching outlets will reduce risk of electric shock.
- **Avoid body contact with earthed or grounded surfaces, such as pipes, radiators, ranges and refrigerators.** There is an increased risk of electric shock if your body is earthed or grounded.
- **Do not expose machine to rain or wet conditions.** Water entering a machine will increase the risk of electric shock.
- **Do not abuse the cord. Never use the cord for carrying, pulling or unplugging the machine. Keep cord away from heat, oil, sharp edges or moving parts.** Damaged or entangled cords increase the risk of electric shock.
- **When operating a machine outdoors, use an extension cord suitable for outdoor use.** Use of a cord suitable for outdoor use reduces the risk of electric shock.
- **If operating a machine in a damp location is unavoidable, use a residual current device (RCD) protected supply.** Use of an RCD reduces the risk of electric shock.

3) PERSONAL SAFETY

- **Stay alert, watch what you are doing and use common sense when operating a machine. Do not use a machine while you are tired or under the influence of drugs, alcohol or medication.** A moment of inattention while operating machine may result in serious personal injury.
- **Use personal protective equipment. Always wear eye protection.** Protective equipment such as dust mask, non-skid safety shoes, hard hat or hearing protection used for appropriate conditions will reduce personal injuries.
- **Prevent unintentional starting. Ensure the switch is in the off-position before connecting to power source and/or battery pack, picking up or carrying the tool.** Carrying machine with

your finger on the switch or energizing machine that have the switch on invites accidents.

- **Remove any adjusting key or wrench before turning the machine on.** A wrench or a key left attached to a rotating part of the machine may result in personal injury.
- **Do not overreach. Keep proper footing and balance at all times.** This enables better control of the power in unexpected situations.
- **Dress properly. Do not wear loose clothing or jewellery. Keep your hair and clothing away from moving parts.** Loose clothes, jewellery or long hair can be caught in moving parts.
- **If devices are provided for the connection of dust extraction and collection facilities, ensure these are connected and properly used.** Use of dust collection can reduce dust-related hazards.
- **Do not let familiarity gained from frequent use of tools allow you to become complacent and ignore tool safety principles.** A careless action can cause severe injury within a fraction of a second.

4) MACHINE USE AND CARE

- **Do not force the machine. Use the correct machine for your application.** The correct machine will do the job better and safer at the rate for which it was designed.
- **Do not use the machine if the switch does not turn it on and off.** Any machine that cannot be controlled with the switch is dangerous and must be repaired.
- **Disconnect the plug from the power source and/or the battery pack, if detachable, from the machine before making any adjustments, changing accessories or storing machine.** Such preventive safety measures reduce the risk of starting the machine accidentally.
- **Store idle machine out of the reach of children and do not allow persons unfamiliar with the machine or these instructions to operate the machine.** Machine are dangerous in the hands of untrained users.
- **Maintain machine and accessories. Check for misalignment or binding of moving parts, breakage of parts and any other condition that may affect the machine's operation. If damaged, have the machine repaired before use.** Many accidents are caused by poorly maintained machine.
- **Keep cutting tools sharp and clean.** Properly maintained cutting tools with sharp cutting edges are less likely to bind and are easier to control.
- **Use the machine, accessories and tool bits, etc. in accordance with these instructions, taking into account the working conditions and the work to be performed.** Use of the machine for operations different from those intended could result in a hazardous situation.
- **Keep handles and grasping surfaces dry, clean, and free from oil and grease.** Slippery handles and grasping surfaces do not allow for safe handling and control of the tool in unexpected situations.

5) BATTERY TOOL USE AND CARE

- **Recharge only with the charger specified by the manufacturer.** A charger that is suitable for one type of battery pack may create a risk of fire when used with another battery pack.
- **Use machine only with specifically designated battery packs.** Use of any other battery packs may create a risk of injury and fire.
- **When battery pack is not in use, keep it away from other metal objects, like paper clips, coins, keys, nails, screws or other small metal objects, that can make a connection from one terminal to another.** Shorting the battery terminals together may cause burns or a fire.
- **Under abusive conditions, liquid may be ejected from the battery; avoid contact. If contact accidentally occurs, flush with water. If liquid contacts eyes, additionally seek medical help.** Liquid ejected from the battery may cause irritation or burns.
- **Do not use a battery pack or tool that is damaged or modified.** Damaged or modified batteries may exhibit unpredictable behaviour resulting in fire, explosion or risk of injury.

- **Do not expose a battery pack or tool to fire of excessive temperature.** Exposure to fire or temperature above 130°C may cause explosion.
- **Follow all charging instructions and do not charge the battery pack or tool outside the temperature range specified in the instructions.** Charging improperly or at temperatures outside the specified range may damage the battery and increase the risk of fire.

6) SERVICE

- **Have your machine serviced by a qualified repair person using only identical replacement parts.** This will ensure that the safety of the machine is maintained.
- **Never service damaged battery packs.** Service of the battery packs should only be performed by the manufacturer or authorized service providers.

RIDE-ON MOWER SAFETY WARNINGS

TRAINING

- When using the product, the safety rules must be followed. For your own safety and that of bystanders, please read these instructions before operating the product. Please keep the instructions safe for later use.
- Allow only responsible adults, who are familiar with and understand the instructions, to use the product.
- Be familiar with the controls and the correct use of the product.
- Always use safety protective devices. Do not use the product without the side discharge chute in place and working properly. The mulch cover should be correctly installed and working properly during mulching operation.
- Be aware of possible hazards when not using the product or when changing accessories. Following this rule will reduce the risk of electric shock, fire, or serious personal injury.
- Never carry passengers or children, even when the blades have stopped. They may fall off and be seriously injured or interfere with the safe operation of the product. Children who have been given rides in the past may suddenly appear in the mowing area for another ride and be run over or backed over by the product
- Keep in mind that the operator or user is responsible for accidents or hazards occurring to other people or their property.
- Never allow children or people with reduced physical, sensory, or mental capabilities or persons not familiar with these instructions to operate, clean, or maintain the product. Local regulations may restrict the age of the operator. Children should be adequately supervised to ensure they do not play with the product.
- Follow the manufacturer's instructions for proper operation and installation of accessories. Use only accessories approved by the manufacturer. The use of other accessories may increase the risk of injury.
- Never interfere with the intended function of a safety device or reduce the protection provided by a safety device. Check the proper operation of the safety devices regularly.
- Never tamper with safety devices. Check the proper operation of the safety devices regularly.
- Never use the product while people, especially children, or pets are within 15m because of the danger of objects being thrown by contact with the blade.
- Do not use the product when there is a risk of lightning.
- Do not operate the product in poor lighting. The operator requires a clear view of the work area to identify potential hazards.
- Keep hands and feet away from the cutting area, which is located under the mower deck and inside the side discharge chute. Keep clear of the side discharge chute opening at all times. Do not reach under the mower deck.
- Follow instructions for changing accessories.

PREPARATION

- Wear heavy, long trousers, long sleeves, and sturdy anti-slip footwear. Do not wear short trousers, sandals, or go barefoot. Avoid wearing clothing that is loose fitting or that has hanging cords or ties.
- Always wear safety glasses with side shields. Use a face mask if operation is dusty. Objects struck by the blade can cause severe injuries to persons. Thoroughly inspect the area where the product is to be used, and remove all rocks, sticks, metal, wire, bones, toys, or other foreign objects. Remember, string or wire may entangle with the blades.
- Before use, always visually inspect the product to ensure that blades, blade nuts, and the cutter assembly are not worn or damaged
- Replace worn or damaged blades and nuts in sets to preserve balance.
- Replace worn or damaged parts before operating the product.
- Never direct discharged material toward anyone. Plan the mowing pattern to avoid discharge of material toward bystanders, roads, sidewalks, windows, and cars. Also, avoid discharging material against a wall or obstruction, which may cause the material to ricochet back toward the operator.

OPERATION

- The product must be started with the user properly seated and behind the steering wheel. Never start the product if:
 - not all four wheels are on the ground
 - the side discharge chute is exposed and is not protected by the bagging kit or mulch cover
 - hands and feet of all persons are not clear of the cutting enclosure
- Disengage the blades when the product is not in use.
- Stop the blade when crossing gravelly surfaces to avoid discharging gravel and rocks . Drive the product slowly and carefully to avoid loss of control.
- Turn on the motor carefully according to instructions, and keep hands and feet away from blades. Do not put hands or feet near or under rotating parts.
- Do not mow in reverse unless absolutely necessary. Always look down and behind before and while reversing.
- Before and while reversing, look behind and down for small children, bystanders, and pets.
- Use extra care when approaching blind corners, shrubs, trees, or other objects including overhanging shrubs, which may block your view.
- Slow down before turning.
- Slopes are a major factor related to loss of control and tip-over accidents, which can result in severe injury or death. Operation on all slopes requires extra caution. If you cannot back up the slope or if you feel uneasy on it, do not mow it. Never use the product on steep slopes greater than 15°. Make a copy or cut out the "Slope Guide" at the back of this manual and use it to determine if your slope is too steep for safe operation.
 - Never attempt to ride on a steep slope or mow a slope that is greater than 15°.
 - Mow up and down; not across the face of slopes.
 - Avoid holes, ruts, bumps, rocks, property stakes, or other hidden objects. Uneven terrain could overturn the product. Tall grass can hide obstacles.
 - Use a slow speed so you will not have to stop suddenly or accidentally accelerate while on a slope.
 - Do not mow on wet grass when on a slope. Tyres may lose traction and you may lose control.
 - Always keep the direction control switch in the forward position when going down slopes. Do not shift to neutral and coast downhill, which may cause you to lose control of the product.

- Avoid starting, stopping, or turning on a slope. If the tyres lose traction, disengage the blades and proceed slowly straight down the slope.
- Keep all movement on slopes slow and gradual. Do not make sudden changes in speed or direction, which could cause the product to roll over.
- Use extra care while using the product with attachments; they can affect the stability of the product. Do not use on steep slopes greater than 15°.
- Do not try to stabilize the product by putting your foot on the ground.
- Do not use the product near drop-offs, ditches, excessively steep slopes, or embankments.
- The product could suddenly roll over if a wheel goes over the edge or if the edges caves in and result in death or serious personal injury.
- Never leave a running product unattended. Always turn off the blades, engage the parking brake, stop the motor, and remove the start key before dismounting.
- Watch for traffic when operating near roadways. Do not operate the mower on roadways.

ADDITIONAL CHARGER SATETY WARNINGS

- The charger is for indoor use only.
- Do not recharge primary cells (non- rechargeable).
- Before every use, examine the supply cord for damage. If there are signs of damage, it must be replaced by a qualified person at an authorized service centre to avoid a hazard.
- Charge the product indoors, in a well ventilated area. Do not charge the product in a confined space.
- The charger is equipped with a plug featuring a grounding pin and must be plugged into a matching outlet that has been properly installed and grounded in accordance with all local codes and ordinances.
- Do not use adapters or modify the plug provided. If it does not fit the outlet, have the proper outlet installed by a qualified electrician.

ADDITIONAL BATTERY SATETY WARNINGS

 **WARNING:** To reduce the risk of fire, personal injury, and product damage due to short circuit, never immerse your tool, battery pack, or charger in fluid or allow a fluid to flow inside them. Corrosive of conductive fluids, such as seawater, certain industrial chemicals, and bleach or bleach-containing products, etc., can cause a short circuit.

 **WARNING:** Risk of fire, explosion, or burns. Do not disassemble, expose to heat above 60°C, or incinerate the battery pack.

- The battery pack contains acid. If acid comes in contact with skin or clothing, flush immediately with water for 10 minutes. If liquid comes in contact with eyes, seek medical help immediately.
- Do not charge battery packs that show signs of leaks. Dispose of them properly.

BATTERY PACK REMOVAL AND PREPARATION FOR RECYCLING

To preserve natural resources, recycle or dispose of batteries properly.

The product contains lead - acid batteries. Local regulations may prohibit disposal of lead-acid batteries in ordinary trash. Consult your local waste authority for information regarding available recycling and /or disposal options.

 **WARNING:** Upon removal, cover the battery pack terminals with heavy-duty adhesive tape. Do not attempt to destroy or disassemble battery pack or remove any of its components. Lead-acid batteries must be recycled or disposed of properly. Never touch both terminals with

metal objects and body parts as short circuit may result. Keep away from children. Failure to comply with these warnings could result in fire and /or serious injury.

TRANSPORTATION AND STORAGE

- Turn off the product, engage the parking brake, and remove the start key. Make sure that all moving parts have come to a complete stop. Allow the product to cool down before storing or transporting.
- Clean all foreign materials from the product. Store the product in a cool, dry, and well-ventilated place that is inaccessible to children. The start key should also be removed and stored in a separate location out of the reach of children.
- Keep the product away from corrosive agents such as garden chemicals and de-icing salts. Do not store the product outdoors.
- Use extra care when loading or unloading the product onto a trailer or truck. Step on the brake pedal as needed to control the speed. The product will freely roll if it is moved on an inclined surface without stepping on the brake pedal or engaging the parking brake. When loading or unloading the product, do not exceed the maximum recommended operation angle of 15°.

 **WARNING:** The product for maintenance, cleaning, storage, or transportation. The blade is sharp. Keep all body parts away from the blade while it is exposed.

TRANSPORTING LEAD-ACID BATTERIES

Transport the battery in accordance with local and national provisions and regulations. Follow all special requirements on packaging and labeling when transporting batteries by a third party. Ensure that no batteries can come in contact with other batteries or conductive materials while in transport by protecting exposed connectors with insulating, non-conductive caps or tape. Do not transport batteries that are cracked or leaking. Check with the forwarding company for further advice.

TOWING SAFETY WARNINGS

 **WARNING:** Use extreme caution when towing the product. The blade is sharp. Keep all body parts away from the blade while it is exposed.

- Use common sense when towing. Too heavy of a load while on a slope is dangerous. Tyres can lose traction with the ground and cause you to lose control of the product.
- Follow the manufacturer's recommendations for wheel weights or counterweights.
- Total towed weight must not exceed the maximum towing load of 226.8 kg (500 lbs.).
- Attach tow equipment only at the hitch plate.
- Never allow children or others on the towed equipment.
- Stopping distance increases with speed and weight of load being towed. Travel slowly and allow extra time and distance to stop.
- Do not turn sharply when towing. Use additional caution when turning or operating under adverse surface conditions. Use care when reversing.

MAINTENANCE

 **WARNING:** Use only original manufacturer's replacement parts, accessories and attachments. Failure to do so can cause possible injury, can contribute to poor performance, and may void your warranty.

 **WARNING:** Servicing requires extreme care and knowledge and should be performed only by a qualified service technician. Have the serviced by an authorized service centre only. When servicing, use only original replacement parts.

- Maintain the product with care and in good working condition. Keep blades sharp and guards in place and in working order. To prevent serious personal injury, prevent damage to the product, and to maintain best performance, replace damaged, bent, cracked, or unevenly worn out blades. An unbalanced blade causes vibration that could damage the motor drive unit or could cause personal injury.
- Never make any adjustments or repairs while the motor is running and the blades are moving.
- Remove the start key from the product before storing, servicing, or changing accessories. Such preventive safety measures reduce the risk of starting the product accidentally.
- Turn off the product, engage the parking brake, and remove the start key. Make sure that all moving parts have come to a complete stop:
 - before leaving the product unattended (including disposal of grass clippings).
 - before clearing blockages or unclogging discharge chute
 - before checking, cleaning, or working on the product
 - before removing the mulch cover
 - before opening the grass discharge chute cover
 - after striking a foreign object
 - thoroughly inspect the product for any damage
 - replace the blade if it is damaged in any way
 - repair any damage before restarting and continuing to operate the product.
 - whenever the product starts to vibrate abnormally (check immediately)
 - inspect for damage, particularly the blades
 - replace the blade if it is damaged in any way
 - replace or repair any damaged parts
 - check for and tighten any loose parts
- You may make adjustments and repairs described in this manual. For other repairs, have the product serviced by an authorized service centre only
- Contact an authorized service centre to replace damaged or unreadable labels.
- Service on the product and the charger must be performed by qualified repair personnel only. Service or maintenance performed by unqualified personnel could result in injury to the user or damage to the product.
- Check all nuts, bolts and screws at frequent intervals for proper tightness to ensure that the product is in safe working condition. The blade bolts must be tightened to the recommended torque. Check the brakes before each use and frequently during use. Adjust and service as required.
- The side discharge chute is a spring-loaded guard that covers the side discharge opening on the cutting deck and deflects grass clippings and debris away from the operator. Always ensure that the motor is off and the blades have stopped moving before inspecting, moving, cleaning, or performing maintenance on the side discharge chute.
- Replace worn or damaged parts for safety.
- Replace damaged blades and bolts in sets to preserve balance. Be careful during adjustment of the product to prevent entrapment of the fingers between moving blades and fixed parts of the product.
- The cutting blades continue to rotate for a few seconds after the motor is shut off. When servicing the blades, be aware that even though the power source is switched off, the blades can still be moved. Never place any part of the body in the blade area until you are sure the blades have stopped rotating.

- The blade on the product is sharp. Use extreme caution and wear heavy-duty gloves when fitting, replacing, cleaning or checking bolt security.
- After each use, clean the product with a soft, dry cloth. Any part that is damaged should be properly repaired or replaced by an authorized service centre.
- Keep the product free of grass, leaves, or other debris build up.
- Do not use water to clean the product. Use an air moving device, such as a compressor or leaf blower to clean the product.

CLEARING BLOCKAGES

- Turn off the product, engage the parking brake, and remove the start key. Set the cutting deck to the maximum height. Make sure that all moving parts have come to a complete stop.
- Always wear heavy-duty gloves when checking or clearing a blockage. The blades are sharp and the blockage itself could be a sharp object.
- Check and carefully clear the side discharge chute for blockages.
- If any blockages are found, remove carefully. Remember the blade may move during cleaning.

RESIDUAL RISKS

Even when the product is used as prescribed, it is still impossible to completely eliminate certain residual risk factors.

The following hazards may arise during use, and the operator should pay special attention to avoid the following:

- Injury caused by vibration
 - Always use the right tool for the job. Use designated handles and restrict working time and exposure.
- Injury caused by exposure to noise
 - Wear ear protection and limit exposure.
- Injury from contact with the blades
 - Keep unprotected body parts away from the blades at all times.
- Injury caused by thrown objects
 - Wear full eye protection at all times.















RISK REDUCTION

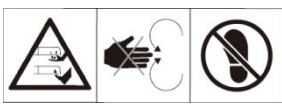

It has been reported that vibrations from handheld tools may contribute to a condition called Raynaud's Syndrome. Symptoms may include tingling, numbness and blanching of the fingers, usually apparent upon exposure to cold. Hereditary factors, exposure to cold and dampness, diet, smoking and work practices are all thought to contribute to the development of these symptoms. There are measures that can be taken by the operator to possibly reduce the effects of vibration: Keep your body warm in cold weather. When operating the product, wear gloves to keep the hands and wrists warm. It is reported that cold weather is a major factor contributing to Raynaud's Syndrome.





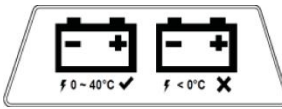











- After each period of operation, exercise to increase blood circulation.
- Take frequent work breaks. Limit the amount of exposure per day.
- If you experience any of the symptoms of this condition, immediately discontinue use and see your physician.





 **WARNING:** Injuries may be caused, or aggravated, by prolonged use of a tool. When using any tool for prolonged periods, ensure you take regular breaks.

2.5 Symbols

	Safety alert
	Read and understand all instructions before operating the product. Follow all warnings and safety instructions.
	Always look down and behind you before and during backing and make sure children, bystanders, and pets are clear of the area.
	Keep all bystanders, especially children and pets, at least 30 m away from the operating area.
	Never carry children or anyone, even when the blades are off.
	Do not operate on inclines greater than 15°. Mow up and down slopes, not across.
	Keep hands and feet away from blade and cutting area. Do not step on the cutting deck or on the side discharge chute.
	Beware of thrown or flying objects. Never carry children or anyone even when the blades are off.
	Wear ear protection.
	Cutting of fingers or hand.
	Do not stare at operating lamp.
 Never give rides. Look out for kids.	Always look down and behind you before and during reversing, and make sure that children, bystanders, and pets are clear of the area.
	The guaranteed sound power level is 100 dB (A).
	Brake step on the brake pedal to stop the product.
	Charging port

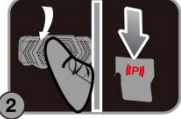
	Lift the blade engagement button up to engage. Press the blade engagement button down to disengage.
	Waste electrical products should not be disposed of with household waste. Please recycle where facilities exist. Check with your local authority or retailer for recycling advice.
	For indoor use only
T15A 	Time - lag fuse type
	Burst hazard
	To reduce the risk of injury or damage, avoid contact with any hot surface.
	Failure to use in dry conditions and to observe safe practices can result in electric shock
	Electric shock hazard.
	Always unplug the charger from the power supply before connecting to or disconnecting from the battery.
	Do not expose to rain or use in damp locations.
	Do not expose to rain or use in damp condition.
	Keep away from all sources of ignition, sparks, and flames. Do not cover any ventilation slots, and provide adequate ventilation during operation.
	Keep out of the reach of children or untrained individuals.
	Wear eye protection.
	The battery pack contains acid. If acid comes in contact with skin or clothing ,flush immediately with water for 10 minutes.
	If liquid gets into your eyes, Flush them with clean water for at least 10 minutes, then seek immediate medical attention.

	<p>Non-spillable. Battery must be recycled.</p>
	<p>The product contains lead-acid batteries. Local regulations may prohibit disposal of lead-acid batteries in ordinary trash. Consult your local waste authority for information regarding available recycling</p>
	<p>Make sure that the side discharge chute is fully closed before operating the product.</p>
	<p>Do not operate the product when the side discharge chute is open.</p>
	<p>Driving the mower</p>
	<p>Insert the start key, and turn the key to the ON position.</p>
	<p>Step on the brake pedal to disengage the parking brake.</p>
	<p>Pull up the blade engage knob to activate the blades.</p>
	<p>Step on the accelerator pedal to mow the lawn.</p>
	<p>Mowing in reverse.</p>
	<p>Step on the brake pedal, and bring the mower to a complete stop.</p>
	<p>Push down the blade engage knob to turn off the blades.</p>
	<p>Press the reverse mode button.</p>
	<p>Pull up the blade engage knob to activate the blades.</p>
	<p>Step on the accelerator pedal, and reverse mow as needed.</p>
	<p>Stopping the mower.</p>

	Stop the mower on a flat level surface. Do not stop the product on slopes.
	Step on the brake pedal, and engage the parking brake.
	Push down the blade engage knob to turn off the blades.
	Turn the key to the OFF position.
	Remove the start key.

3. ASSEMBLY

ASSEMBLY SAFETY RULES

⚠️ WARNING: Strictly adhere to all torque wrench tightening specifications. Failure to do so could cause serious personal injury.

All information, illustrations, photographs, and specifications contained in this manual are based on the latest product information available at the time of publication. Due to improvements or other changes, there may be some discrepancies in this manual. We reserve the right to make product changes at any time, without notice and without incurring any obligation to make the same or similar changes to any products previously built or sold.

- Any person attempting to assemble the product must have proper training and experience. Read this manual carefully and follow all assembly procedures in this manual.
- All assembly must be completed with the product on a level surface.

REQUIRED TOOLS

- Torque wrench.
- Tire pressure gauge.
- Socket wrench.

UNPACKING (See Fig. 1)

- Remove the bolts securing the corner and side braces to the frame bottom, then lift the braces to remove.
- Cut the nylon straps securing the front and rear wheel axles to the frame.
- Remove the boxes containing loose parts, assembly hardware, and documentation.
- Remove and set aside all accessible packaging and wrap from the unit and parts. Do not discard the packing material until you have carefully inspected and satisfactorily operated the product.

⚠️ WARNING: If any parts on the "Loose parts list" section are already assembled to the product when you unpack it, verify that the part is assembled correctly, is properly tightened, and is torqued correctly (where applicable) before proceeding to the next assembly step. Use of a product that may have been improperly assembled could result in serious personal injury.

- Inspect the product carefully to ensure that no breakage or damage occurred during shipping.
- If any parts are damaged or missing, contact an authorized service centre.

NOTE: The product should be assembled while positioned on the frame bottom. Once assembly is complete, set the cutting deck to its maximum height, then position a ramp next to the frame bottom, and slowly and carefully drive the product off the frame.

⚠️WARNING: Use care when driving the product off or the frame, and step on the brake pedal as needed to control the speed. The product freely rolls if it is moved on an inclined surface without stepping on the brake pedal or engaging the parking brake. Failure to follow these instructions can result in loss of control and result in death, serious personal injury, or property damage.

⚠️WARNING: If no ramp is available, slowly and carefully drive the product off the frame in reverse while looking down and behind. Driving the product off the frame in the forward direction without a ramp can cause damage to the cutting deck.

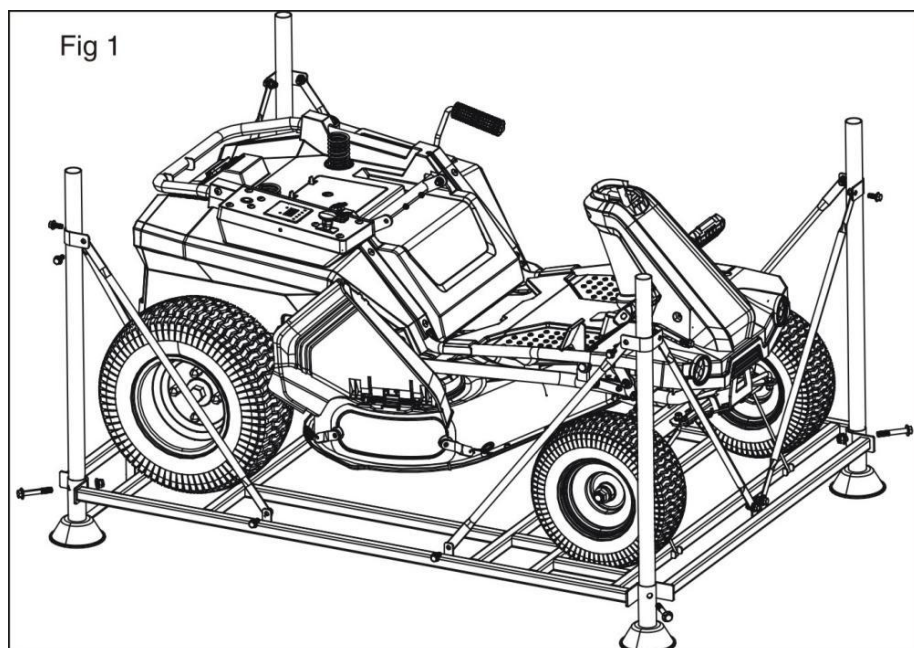

LOOSE PARTS LIST (See Fig. 2-7)

⚠️WARNING: If any parts are damaged or missing do not assemble the product until the parts are replaced with new original manufacturer’s parts. Assembling the product with damaged, missing, or incorrect parts could result in serious personal injury.

No.	Part name	Quantity	No.	Part name	Quantity
1	Seat assembly	1	2.8	Steering column	1
2	Steering column assembly	1	3	Battery charger	1
2.1	Steering wheel cover	1	4	Start keys	1
2.2	Flange nut	1	5	Decorative tube	1
2.3	Flat washer	1	6	Tool	1
2.4	Steering wheel	1	6.1	Wrench10-13	1
2.5	Steering wheel hub	1	6.2	Wrench13-15	1
2.6	Flange Washer	2	6.3	Allen wrench	1
2.7	Bushing	1	6.4	Manual	1

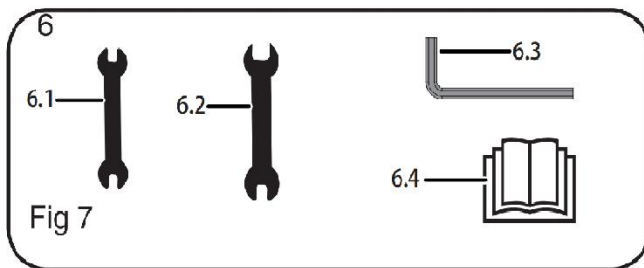
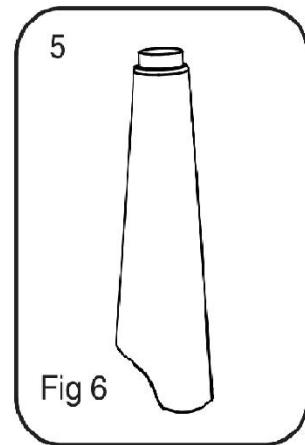
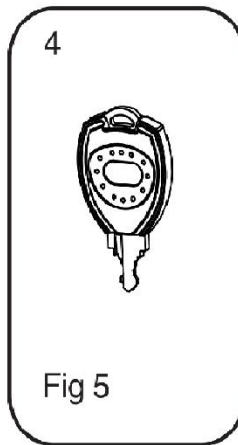
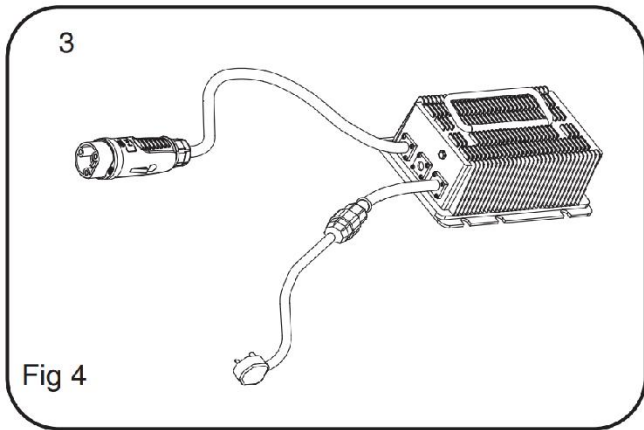
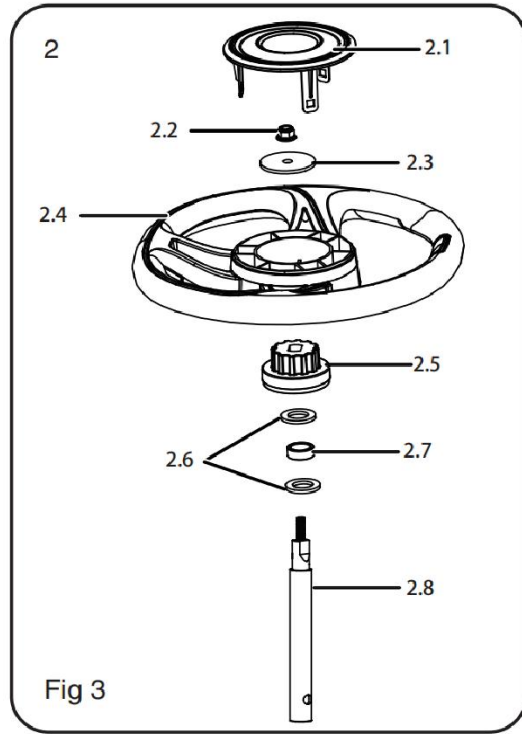
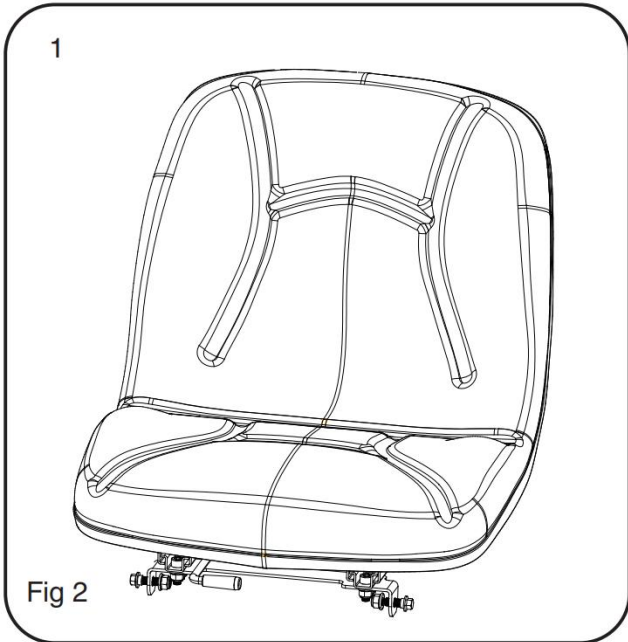

⚠ WARNING: Strictly adhere to all torque wrench tightening specification. Failure to do so could cause serious personal injury.

⚠ WARNING: Do not attempt to modify the product or create accessories not recommended for use with the product. Any such alteration or modification is a misuse and could result in a hazardous condition leading to possible serious personal injury.

⚠ WARNING: To prevent accidental starting that could cause serious personal injury, always remove the start key from the product when assembling the parts.

CONNECTING THE BATTERY (See Fig. 8)

When shipped from the factory , the product's batteries are disconnected.

To connect:

- Press the tabs on the wiring cover and lift the cover to remove.
- Connect the two ends of the battery quick connect plug together.

NOTE: Before reinstalling the wiring cover, install the seat as described in the next section.

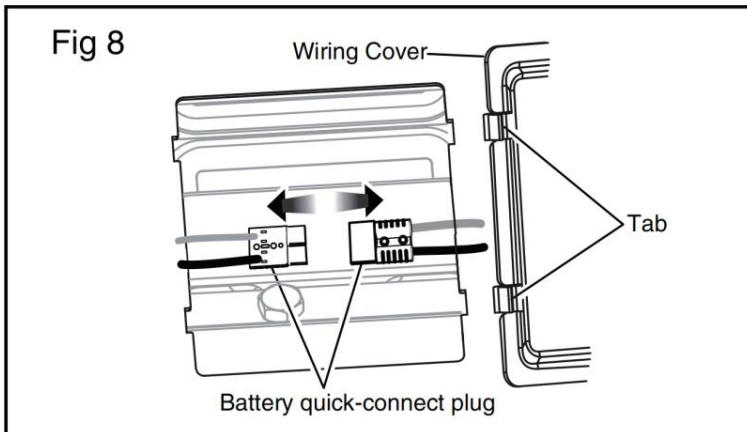

INSTALLING THE SEAT (See Fig. 9)

- Remove the bolts and flange nuts from seat mounting brackets.
- Place the seat assembly over the mounting brackets, aligning the holes as shown.
- Reinstall and securely tighten the bolts and flange nuts.
- Route the seat safety interlock cable through hole in the wiring cover, then connect to the plug on the mower.
- Reinstall wiring cover, and ensure that it is securely seated.

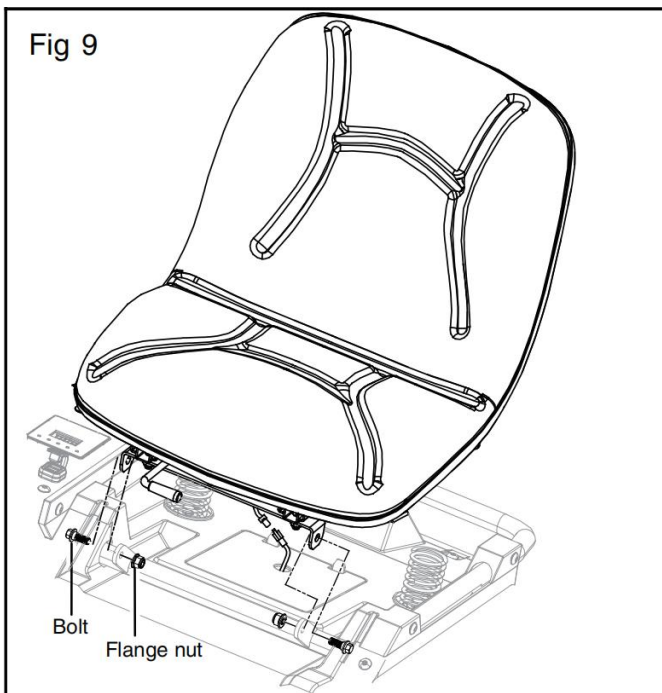

INSTALLING THE STEERING COLUMN (See Fig.10)

- Put the shaft into the lower steering rod to align the shaft and lower steering rod mounting holes. After inserting the bolts, tighten them with Flange nut. The recommended torque is $25\pm 2\text{N.m}$.
- After installing the shaft, put the decorative tube on the shaft ,
- Put flange Washer, bushing, flange Washer, Steering wheel hub on the shaft,
- Then install steering wheel and flat washer in the order and direction as shown in the figure. The mounting points of the steering wheel and the steering wheel base are aligned and fixed with flange nut. The recommended torque is $24\pm 2\text{N.m}$;

- finally install Steering wheel cover on steering wheel

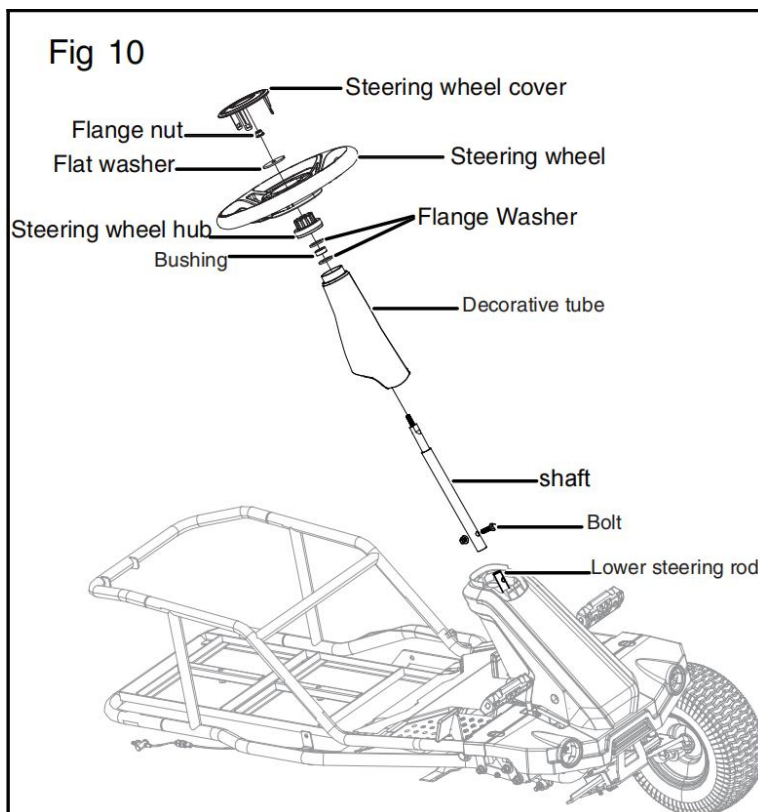

CHARGING THE PRODUCT (See Fig.11)

Mower batteries must be charged overnight before first use. To verify mower batteries are fully charged, check the battery level indicator.

For best results:

CHARGING LED INDICATOR

- Make sure both the charger and mower connections are clean and free of dirt or debris.
- Insert charger plug into charging port on mower, making sure it is properly connected.
- Charger input power specification: AC 100V~ 240V, frequency 50/60Hz

NOTE: The charger is equipped with a plug featuring a grounding pin and must be plugged into a matching standard three prong outlet that has been properly installed and grounded in accordance with all local codes and ordinances. Do not use a two prong outlet, adapters, or modify the plug provided. If it will not fit the outlet, have the proper outlet installed by a qualified electrician.

· When powered, the LED indicator on the charger will illuminate to indicate the charger's status.

See the chart that follows to determine the meaning of the LED's display.

· When you are ready to mow, disconnect the charger from the power supply, then disconnect the charger from the mower.

· If the machine is stored unused for a long time, in order to prolong the service life of the battery, it is recommended to charge it once every three months.

· When charging, first connect the wire between the power supply and the charger, and then connect the charger and the machine.

· If there is a filter, connect the filter between the power supply and the charger when charging.

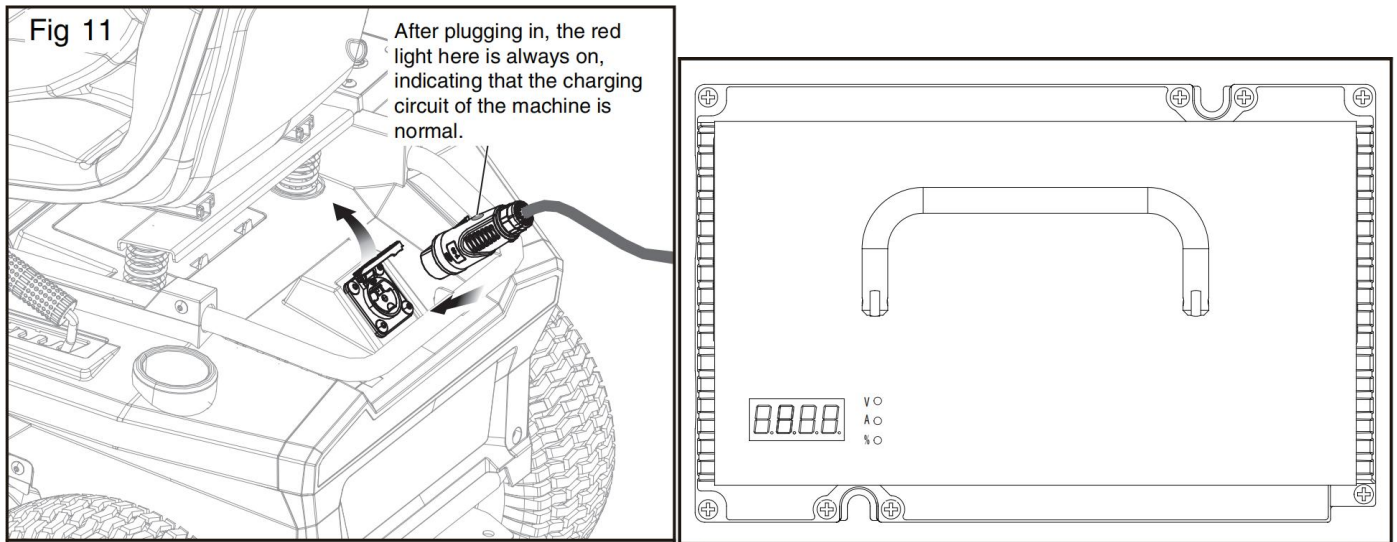

CHARGING LED INDICATOR

LED indicating lamp	Battery/charger status
A	Current charging current
V	Current charging voltage
%	Battery percentage

4. FEATURES

Know the product (See Fig.12)

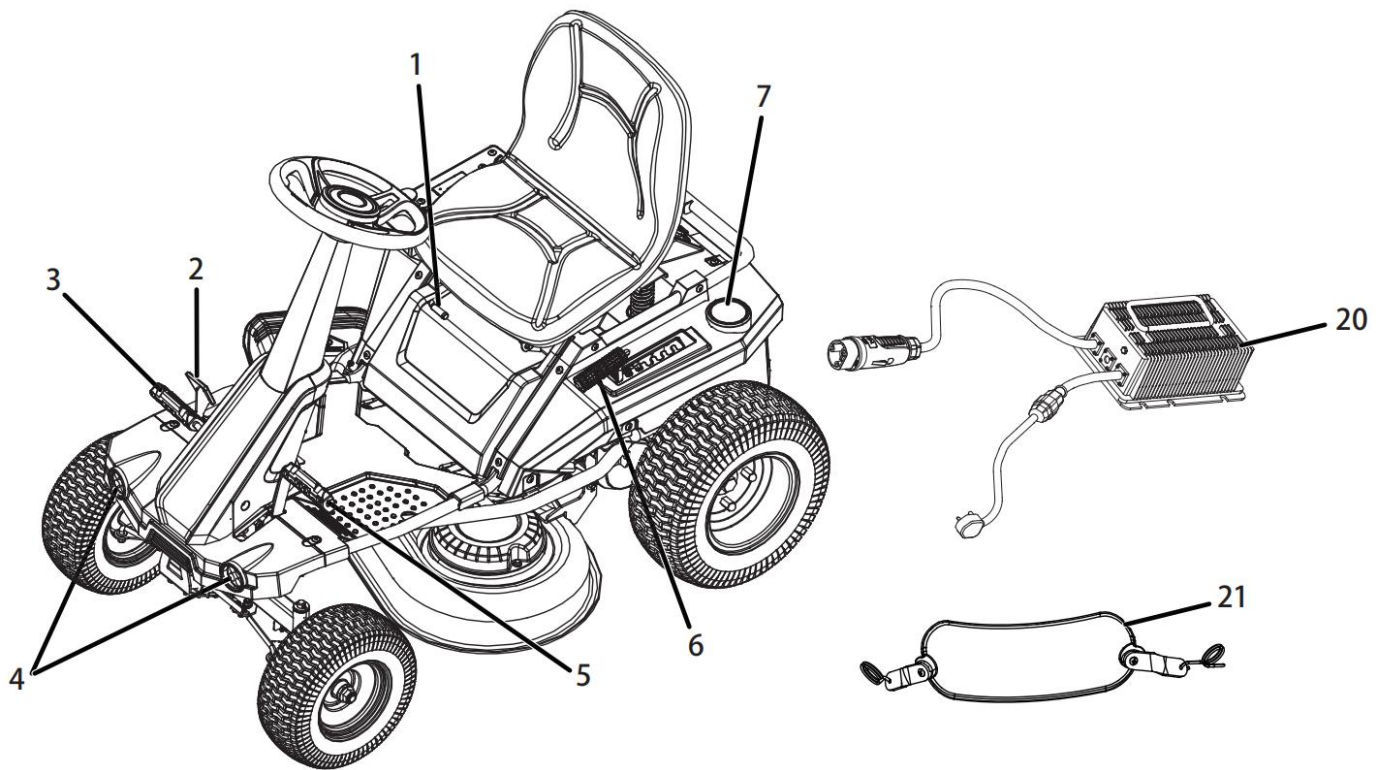

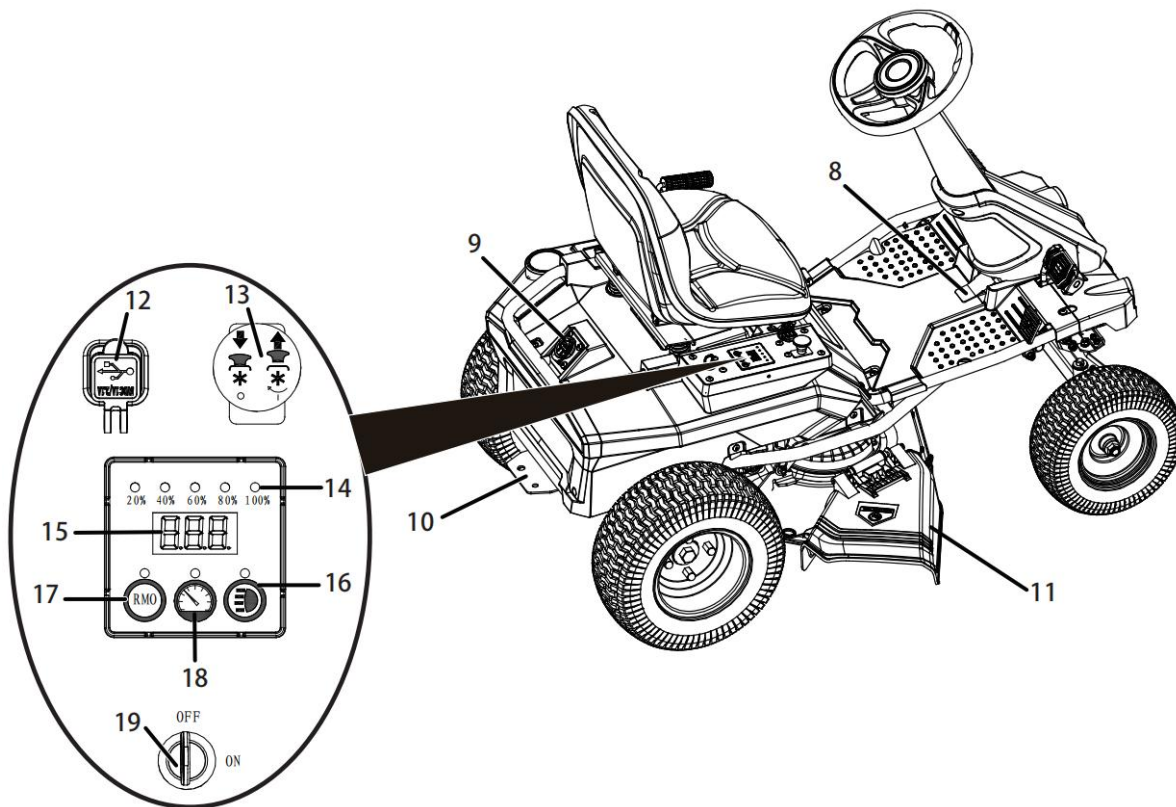

NO.	Name	Function & Purpose
1	Seat Adjustment Lever	Rotate the seat adjustment lever to adjust the front and rear position of the seat.
2	Reverse Pedal	The back pedal controls the back movement and speed of the riding mower.
3	Accelerator Pedal	The forward pedal controls the forward movement and speed of the riding mower.
4	Headlight	To provide lighting.
5	Brake Pedal	The brake pedal is used to slow down and stop the movement of the riding mower.
6	Cutter head Lifting Handle	Used to raise or lower the height of the mowing disc.
7	Cup Holder	Used to hold cup.
8	Parking Pedal	Step on the parking pedal and then the brake pedal. After hearing the sound, the riding mower will be locked in the braking position.
9	Charging Socket	Use with charger to charge riding mower.
10	Trailer board	Used in conjunction with a trailer for easy towing.
11	Side Exhaust Duct	Used to guide the shredded grass blown out from the side discharge port.
12	USB Socket	The USB charging port can provide Total 5V 2A DC power to your mobile phone, MP3 or other USB devices.
13	Mower Motor Switch	Lift the switch upwards, the riding mower blades will start; press the switch, the riding mower blades will stop. Note that you must first press the RMO button before going back to mowing.
14	Battery Indicator	To show remaining battery.
15	Timer	To record the running time of the riding mower.
16	Headlight Switch	To control the headlights to turn on and off.

17	Reverse Mowing Mode Switch	When the RMO button is pressed and the indicator light is on, then lift the blade motor switch, and the riding mower can cut the grass during the backward process. If you press the RMO button again, the indicator light goes out, and the backward mowing function is canceled. If the RMO button is not pressed, the blade motor will not start when moving back.
18	Cruise control button	During in forward driving, press the cruise control button, the machine will keep the current speed and drive at a constant speed, and there is no need to keep pressing the forward pedal.
19	Power Switch	The power switch is used to disconnect and switch on the power of the riding mower. First insert the start key and turn it to "ON" to operate the riding mower. If the key is an accessory, other models of riding mowers approved by the manufacturer can also use this key as a power switch.
20	Charger	The charger of the riding mower has a keyhole suspension function, which is convenient to save space for storage. When hanging through the keyhole slot, at least one hole is fixed in place with a screw. When installing the keyhole suspension, make sure that the charger's LED light is in a visible position for charging.
21	Shredded Grass Baffle	To block the side discharge port, so that the grass can be cut into smaller pieces in the cutter head.

Product specifications

Model:	FRE7548V
Mowing motor power	1.2kW
Maximum operating engine speed	3500/min
Voltage output	DC 48V
Cutting height adjustment	38mm-114mm
Driving motor	1.0 kW
Max driving speed-(non-loading)	8km/h
Max driving speed-(Forwarding):	8km/h
Max driving speed-(Reverse):	3.2km/h
Tire pressure:	22±2 PSI
Front/rear wheel size:	13"/16"
Blade:	831032 385mm±2
Cutting width:	762mm
Net weight (Kg)	165
Sound pressure level	89.4 dB, K: 3dB(A)
Sound power level	99.4 dB, K: 1.08dB(A)
Guaranteed Sound Power level	100 dB
Hand-arm vibration	<2.5m/s ² , K: 1.5 s ²
Whole body vibration	<2.5m/s ² , K: 1.5 s ²
Battery Charger	
Model:	PHIC480080D
Rating(PHIC480080D)	Input:AC 100-240V, 50/60Hz, 6A max Output:DC 48V 8Amax

Allowable charging temperature range	-10-40°C
Battery	
Model:	6-EVF-50B (Sealed Lead-acid battery)
Technical data:	12V, 50Ah per cell, 4 cells connected in series
Charging time:	8 h

Before starting the check

Remove any objects in the work area that may be knocked up or entangled by the blade.

- Check whether the brake is normal.
- Check tire pressure.
- Check if the fasteners are loose.
- Check that all protective devices are installed in place and work normally.
- Clean up debris and broken grass on the riding mower.
- Test the safety interlock system.
- Adjust the seat to a suitable position.
- Check the battery level.

Note: When the battery power is lower than 25%, the mowing motor will automatically shut down. Please return to charge immediately. Electricity. When the battery power is less than 25%, continuing to mow the lawn may cause the riding mower to run aground; if the grass cart is stranded, please press the blade motor switch, turn off the power switch, and push the riding mower back to the charging position.

⚠ WARNING

Before operating the riding mower, remind people around to leave the mowing area. If someone enters the mowing area, please turn off the machine immediately, then continue mowing until person leave mowing area.

Installing the mulch cover (See Fig.13)

The mower is configured for side discharge when shipped. If mulching is desired: Lift the stud and then raise the side discharge chute.

- Place the mulch cover on the tab on the mower housing.
- Connect the mulch cover latches to the two side mounting points on the mower deck housing.
- Release the side discharge chute.

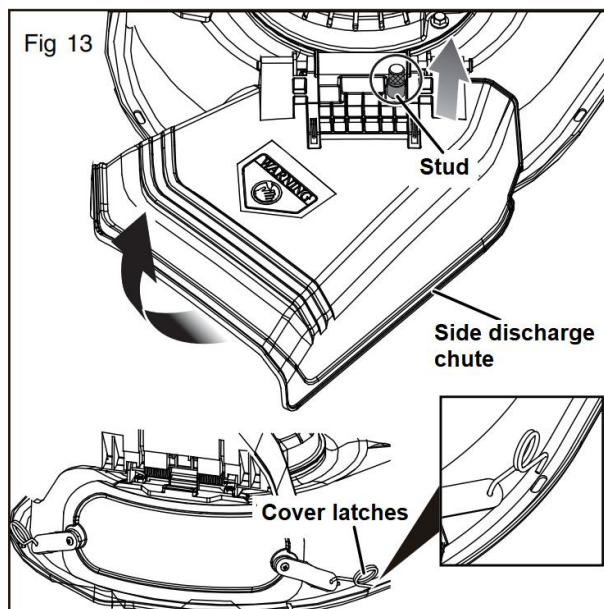

⚠ WARNING

After the assembly is complete, make sure that the shredded grass baffle is installed in place, otherwise may cause serious personal injury.

Engaging the parking brake (See Fig.14)

- Fully depress and hold the brake pedal and depress the parking brake at the same time. Or firstly, depress the parking brake, then fully depress the brake pedal.
- Release the brake pedal.
- Release the parking pedal.
- Turn off the machine and take out the key.
- If you need to unlock the parking brake, depress the brake pedal forcefully and hear a "click" or the parking brake pedal bounces, indicating that the unlocking is successful.

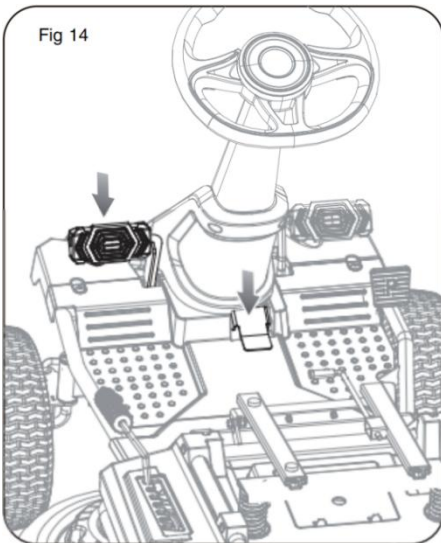

⚠ WARNING

Never leave the mower unattended when the motor is running. Verify that the parking brake is set and the key has been removed. Failure to set the parking brake could cause the mower to move, and leaving the key could allow unauthorized use that could result in serious personal injury.

Adjusting the seat (See Fig.15)

Before operating the riding mower, adjust the seat position to ensure that your feet can step in the accelerator pedal or brake pedal firmly.

To move the seat:

- Turn key to OFF position and set the parking brake.
- Sit down on seat and lift the seat adjustment lever.
- While holding the lever, slide the seat to the desired position.
- Release the lever and make sure the seat is locked in position before operating the mower.

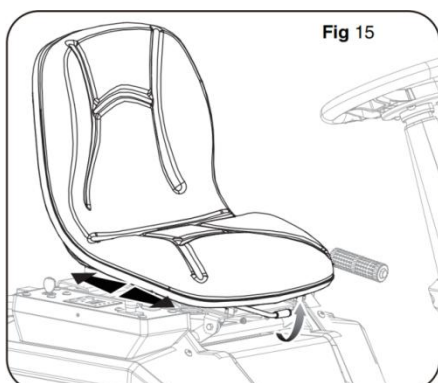

⚠ WARNING

Be sure the seat is locked into place before operating the mower. A seat that is not secure can cause the operator to shift and lose control of the mower and result in possible death or serious personal injury.

Setting the cutting deck height (See Fig.16)

Before using the riding mower, raise the height of the cutter head to the most suitable cutting position for your lawn.

Note: In order to prevent the cutting blade from touching the ground at the highest point of the lawn during the mowing process, the knife The pan is at least 1 inch above the ground. During equipment transportation, set the height of the cutter head from the ground Set to 3 inches. You can change the height of the cutting blade according to the height of the mowing you need. For detailed operation, please refer to the part of adjusting the mower in the maintenance chapter of this manual.

Adjust the height of the mower:

- Stop the mower and disengage blades.
- Turn key to OFF position and press the parking brake.
- To raise the cutting deck, grasp the deck height adjustment lever, push left to disengage from slot, move toward the back of the mower, then push right into slot to secure.
- To lower the cutting deck, grasp the deck height adjustment lever, push left to disengage from slot, move toward the front of the mower, then push right into slot to secure.

Note: When setting the height of the cutter head, grasp the handle of the height adjustment lever, only when it is fixed Release your hand only when you are in the required card slot. If the adjustment lever is released quickly, it may cause a danger of squeezing or pulling the operator's hand.

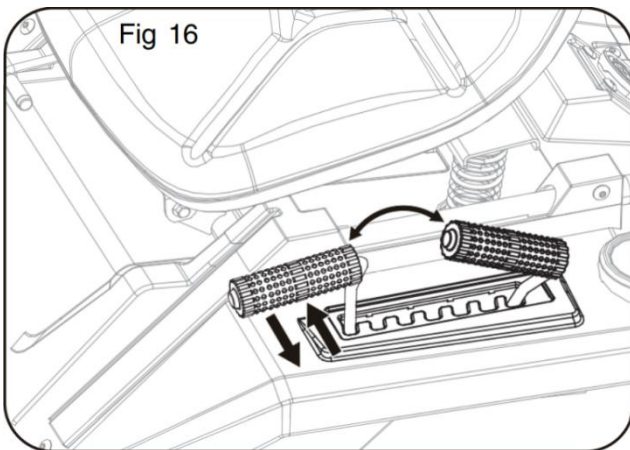

Setting the cruise control (See Fig.17)

Cruise control allows the mower to remain at a constant speed without the operator having to maintain pressure on the accelerator pedal. It should only be used in the forward position on relatively smooth, straight surfaces, and should never be used on slopes or rough terrain. To set the cruise control:

- While driving the mower forward, press the accelerator pedal until the desired rate of speed is achieved.
- Press the cruise control button. The light around the button will illuminate to show cruise control is active.

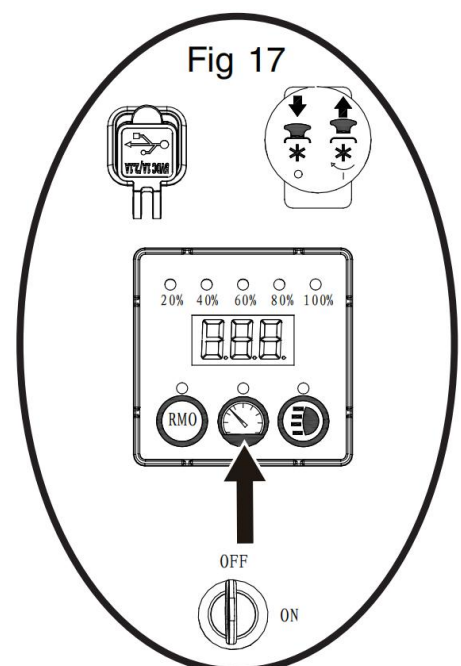

- Release pressure on the accelerator pedal. Mower speed should remain constant.
- To release cruise control: tap on the accelerator pedal, depress the brake pedal, or press the cruise control button again. The light around the cruise control button will go out to indicate cruise control is no longer active.

5. USING THE PRODUCT

WARNING

Clear the area of bystanders before operating the product. If anyone enters the mowing area, stop immediately and do not return to mowing until the bystanders leave the area.

Before starting the product (See Fig.18-19)

- Insert the power switch key and turn it to the "ON" position. The machine will complete the system self-check within 3 seconds and a beep will indicate the completion of the self-check, and the machine will be able to start after the self-check is completed.
- Ensure that the work area is clear of children, bystanders, and pets.
- Clear the work area of objects that may be thrown by the mower blades.
- Check the brake operation.
- Check the tyre pressure.
- Check for loose fasteners.
- Make sure that all guards are in place and working properly.
- Clean debris from mower.
- Check the side discharge chute safety interlock system.
- Test the operator presence safety interlock system.
- Adjust the seat to the preferred position.
- Verify the battery charge level.

WARNING

When the level of battery charge reaches the red zone on the battery charge indicator, the blades automatically stop. Immediately return to the charging location, and recharge the mower. Continuing to mow when the battery charge level is in the red zone causes the mower to be stranded away from the charging area.

NOTE: If the mower is stranded away from the charger, set the direction control switch to the neutral (N) position, and push the mower back to the charging location.

Mowing:

- Set the cutting deck to the maximum height.
- Insert start key and turn the key to the ON position.
- Disengage the parking brake.
- Set the direction control switch in forward (OFF) position, and drive to desired mowing location.

WARNING

Be certain that you have correctly set your intended direction of travel with the direction control switch before pressing the accelerator pedal. Failure to do so could result in you driving the mower in an unintended direction, which could cause loss of control or an accident resulting in death, serious personal injury, or property damage.

- Stop the mower, engage the parking brake, and turn the start key to the OFF position.

- Set the cutting deck to the preferred position.
- Turn the start key to the ON position, and disengage the parking brake.
- Pull up the blade engage knob to activate the blades, and step on the accelerator pedal to mow the lawn.

⚠ WARNING

Use caution when crossing over gravelly paths or driveways. Before crossing, stop the blades and set the cutting deck to the maximum height to minimize the possibility of ricochet. Drive slowly to avoid loss of traction and control.

⚠ WARNING

Do not attempt to change the direction of operation while the mower is in motion. Always come to a complete stop before changing the mower direction.

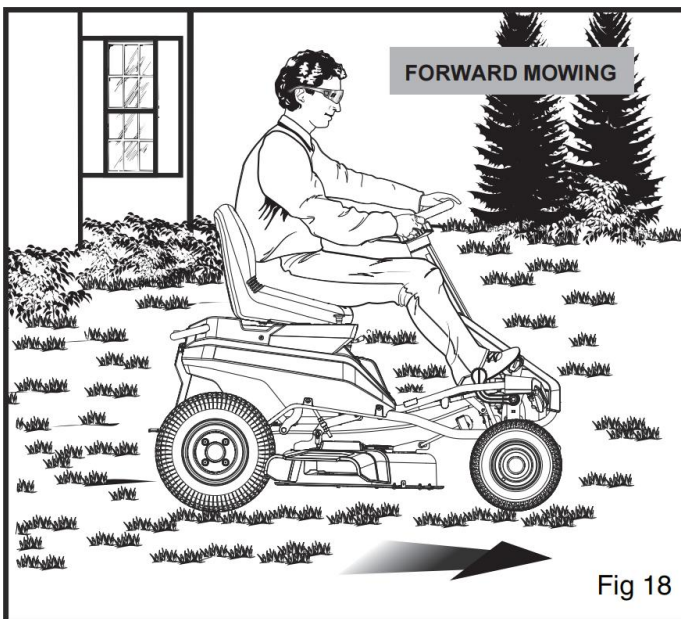

Fig 18

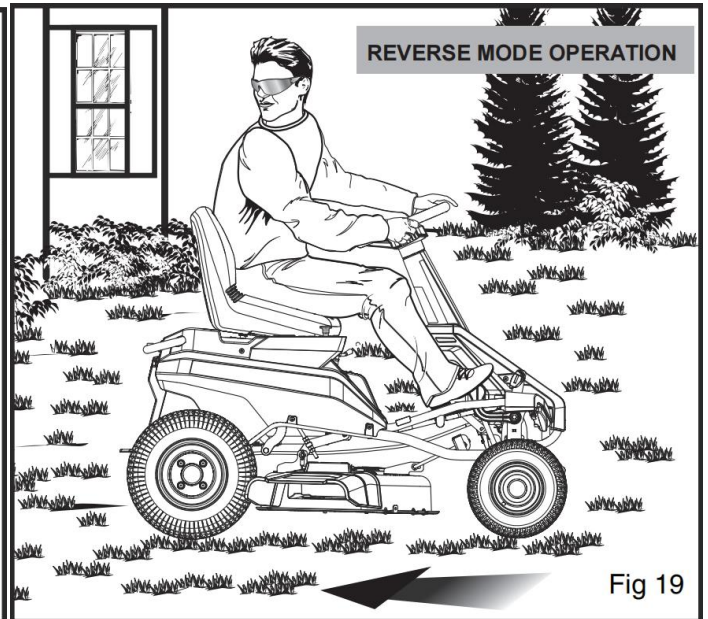

Fig 19

Reverse mode operation (See Fig.20)

- Depress the brake pedal to bring the riding mower to a complete stop.
- Press the blade motor switch to confirm that the blade stops rotating.
- Press the "RMO" button to confirm that the indicator light is on.
- Release the brake, pull up the switch of the blade motor, slowly step on the back pedal, according to Need to control the retreat direction and mowing range.

⚠ WARNING

The product will emit a constant beeping sound when operated in reverse with either the blade off or in reverse mode operation.

NOTE: Reverse mode operation resets each time the power switch is turned to the OFF position.

⚠ WARNING

Do not mow in reverse unless absolutely necessary. Always look down and behind before and while backing to make sure no children, bystanders, or pets enter the mowing area. Be aware that the reverse mode operation is activated when the reverse mode button is illuminated in red and a constant beeping sound is emitted. Remember that a careless fraction of a second is sufficient to inflict death or serious injury.

When mowing is complete:

- Stop mower on a flat, level surface. Do not stop the mower on a slope.
- Push the blade engage knob down to turn blades off.

- Set the parking brake.
- Turn the start key OFF.

⚠ WARNING

If the mower emits a beeping noise after you leave the seat, verify that the parking brake is set and the key has been removed. Failure to set the parking brake could cause the mower to move, and leaving the key could allow unauthorized use that could result in serious personal injury .

MOWING TIPS (See Fig.21)

- Keep mower blades sharp.
- Make sure the lawn is clear of stones, sticks, wires, toys, tree nuts, tree branches, and other objects that could damage the riding mower blades or motor. Do not mow over property stakes or other metal posts. Such objects could damage the blade or be accidentally thrown by the mower in any direction and cause serious personal injury to the operator and others.
- For a healthy lawn, always cut off one-third or less of the total length of the grass.
- When mowing large areas, start by turning to the right so that clippings will discharge away from shrubs, fences, driveways, etc. After one or two rounds, mow in the opposite direction, making left hand turns until finished.
- Mow so that discharged clippings exit in the direction of the lawn area that has already been cut.
- When cutting heavy grass, reduce speed to allow for more effective cutting and a proper discharge of the clippings.
- Do not cut wet grass. It will stick to the underside of the deck and prevent proper bagging or mulching of grass clippings.
- New or thick grass may require a narrower cut or a higher cutting height.
- Keep the mower deck and side discharge chute clean. Remove grass clippings, leaves, dirt, and any other accumulated debris before and after each use. Do not spray with a garden hose to clean.

NOTE: Always stop mower, allow blades to completely stop, and remove the start key before cleaning underneath the mower.

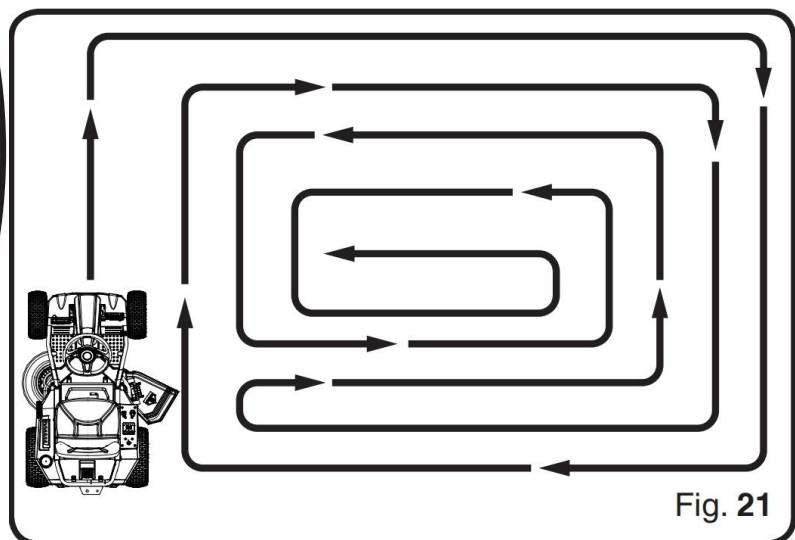
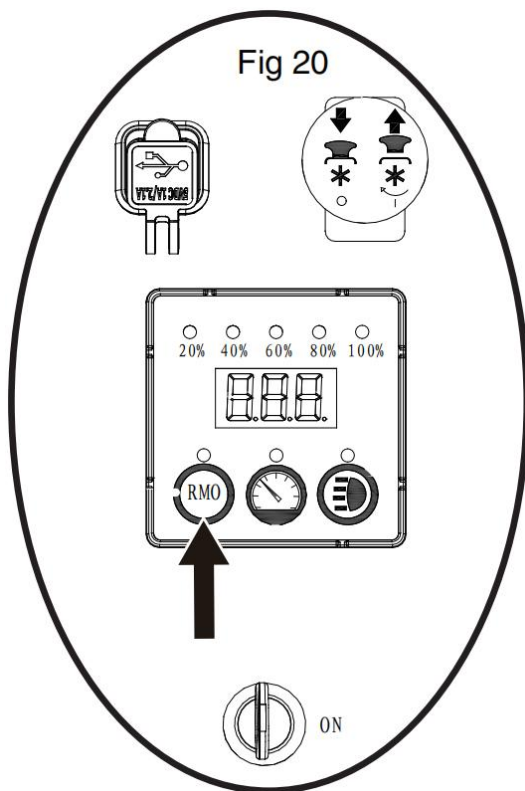

SLOPE OPERATION (See Fig.22)

- Mow up and down, not across the face of slopes.
- Do not mow on wet grass. Wet grass can cause the tires to lose traction or slip on slopes, even though the brakes are functioning properly.
- Watch for holes, ruts, rocks, hidden objects, or bumps which can cause you to slip or trip. Tall grass can hide obstacles. Remove all objects such as rocks, tree limbs, etc., which could be tripped over or thrown by the blade.
- Do not mow near drop offs, ditches, or embankments.
- Drive slowly and do not make sudden changes in speed or direction.
- Avoid stopping on slope if possible. If stopping is unavoidable, make sure to engage parking brake. When restarting, use lowest possible speed. If turning is necessary, exercise extreme caution when changing direction and always turn downhill.
- Never attempt to stabilize the mower on a slope by placing your foot on the ground during operation.
- If using the optional bigger kit, use extreme caution and operate the mower slowly when operating on slopes, as the bagging kit can change the stability of the mower.
- Always use the brakes when travelling down the slope. Do not attempt to let the mower coast downhill in neutral.
- If at any point the tires lose traction while operating on a slope, disengage the blades and proceed slowly and carefully straight down the slope.

⚠ WARNING

Slopes are a major factor related to tip-over and rollover accidents that can result in severe injury or death. Operation on slopes requires extra caution. If you feel uneasy on a slope, do not mow it. For your safety, do not attempt to mow steep slopes greater than 15 degrees. Make a copy or cut out the slope guide image on and use to determine if your slope is too steep for safe operation.

Fig. 22

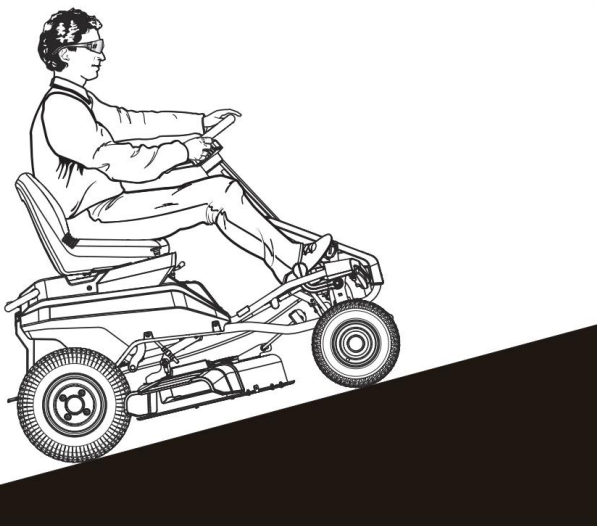

6. TRANSPORTING THE PRODUCT

TRANSPORTING THE PRODUCT (See Fig.23)

- Park the mower on a level surface.
- Raise the cutting deck to the highest position.
- Position and secure ramp to the trailer according to manufacturer's instructions. Slowly drive the mower onto the ramp and into the trailer.
- Lower mower deck completely.
- Set the parking brake.
- Turn off mower and remove key.
- Secure the mower as needed using straps or cables to prevent movement during transport.

NOTE: We recommend you use one full width loading ramp that is at least 1 ft. wider than the mower to minimize the risk of the mower's wheels going off the side of the ramp.

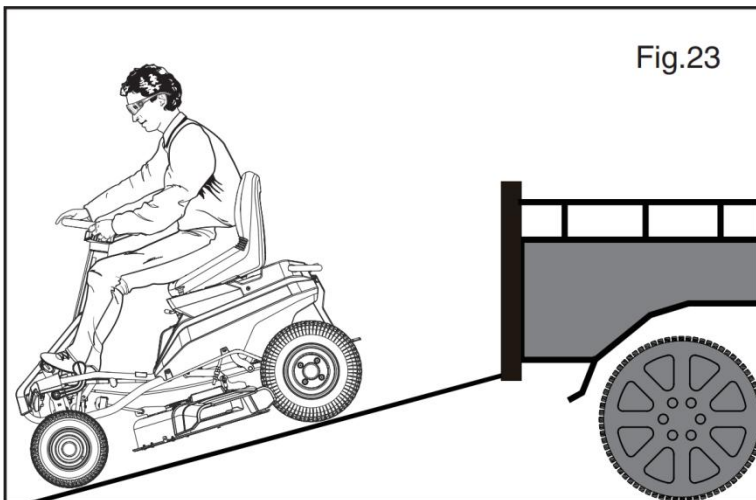

⚠ WARNING

Use care when driving the mower off of or onto a trailer or truck and press the brake pedal as needed to control the speed. The mower will freely roll if it is moved on an inclined surface without pressing the brake pedal or setting the parking brake. Failure to follow these instructions can result in loss of control and result in death, serious personal injury, or property damage.

⚠ WARNING

Use care when loading or unloading the mower onto a trailer. Ensure the cutting deck is raised to the highest position so that it is not caught on the ramp. The wheels on the mower can go off the ramp or trailer, causing the mower to pivot or tip over, and result in a crush hazard that can cause death or serious personal injury.

⚠ WARNING

To avoid accidental starting or movement that could result in serious personal injury, always remove the start key and set the parking brake when transporting the mower.

7. MAINTAINING THE PRODUCT

WARNING

Before performing any maintenance, stop the mower, wait for the blades to come to a complete stop, and remove the start key to avoid accidental starting and possible serious personal injury.

WARNING

Always wear eye protection with side shields marked to comply with ANSI Z87.1. Failure to do so could result in objects being thrown into your eyes resulting in possible serious injury.

WARNING

When servicing, use only authorized replacement parts. Use of any other parts can create a hazard or cause product damage.

WARNING

Strictly adhere to all torque wrench tightening specifications. Failure to do so could cause serious personal injury.

NOTICE: Before each use, inspect the entire product for damaged, missing, or loose parts such as screws, nuts, bolts, caps, etc. Tighten securely all fasteners and caps and do not operate this product until all missing or damaged parts are replaced. Please contact customer service or an authorized service center for assistance.

General maintaining

Avoid using solvents when cleaning plastic parts. Most plastics are susceptible to damage from various types of commercial solvents and may be damaged by their use. Use clean cloths to remove dirt, dust, oil, grease.

WARNING

Do not at any time let brake fluids, gasoline, petrol rum based products, penetrating oils, come in contact with plastic parts. Chemicals can damage, weaken, or destroy plastic which can result in serious personal injury.

Remove any buildup of grass and leaves on or around the motor cover. Wipe the mower clean with a dry cloth occasionally. Do not use water.

Removing the cutting deck (See Fig.23)

If desired, the cutting deck can be removed from the mower to make accessing the blades easier when changing.

- Before disassembly, press the blade motor switch.
- Turn the power switch to "OFF", remove the switch key, and set the parking brake.
- Lower the position of the deck to the lowest level, and disconnect the wire connecting the riding mower motor and the riding mower. Rotate the cable counterclockwise to lock, and turn clockwise to loosen. Note when installing The left cutting deck wire connects to the right controller line, the right cutting deck wire connects to the left controller line.
- Remove the three lock pins, gaskets and pin shafts of the fixed cutting deck in sequence.
- Slide the cutting deck out from under the riding mower. At this time, a staff member is also needed to stabilize Fixed lifting handle to prevent rebound from falling out.

- If you need to reinstall the cutting deck, install the cutting deck back to the riding mower in the opposite direction of the slide out.

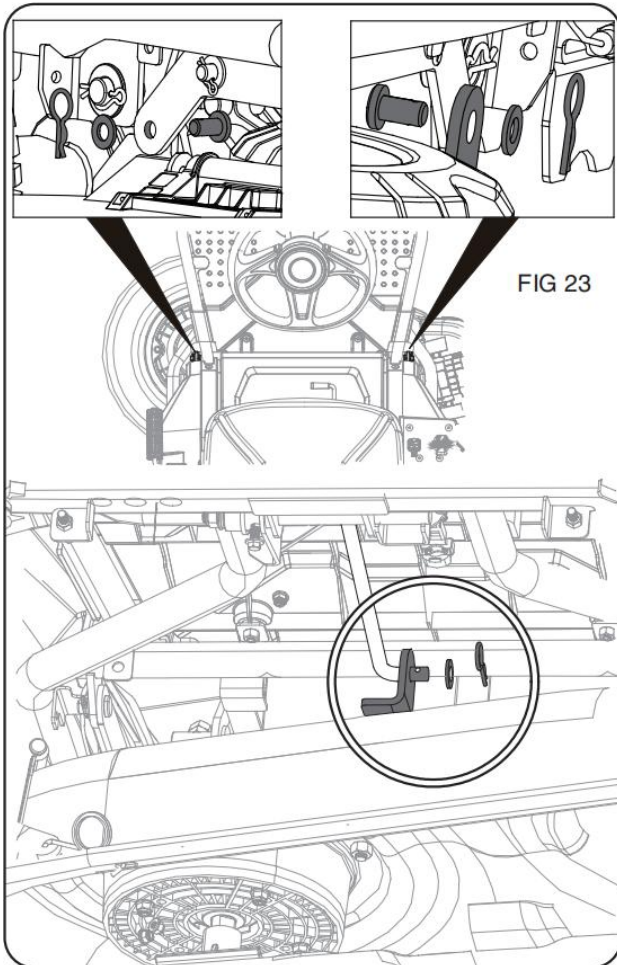

Replacing the cutting blades (See Fig.24-25)

WARNING

Only use replacement blades and blade bolts authorized by the manufacturer of your riding mower. Use of blades and blade bolts not authorized is hazardous and may damage your riding mower.

- Place the machine on a stable ground and press the blade motor switch.
- Turn off the power of the machine, remove the switch key, and set the parking brake.
- Remove the cutter head as described in the previous section and replace the blade as shown below.

Note: When removing and replacing the cutter head and blades, at least two people are required to work together.

WARNING

If raising the mower to access the blades, make sure the mower is properly secured and the parking brake is set before proceeding. Failure to properly secure the mower could cause it to fall, resulting in death or possible serious personal injury.

- Insert a wooden board between the blade and the wall of the cutter head of the mower to prevent the blade from rotating.

- Use a 15mm wrench or socket to turn the blade bolt counterclockwise (viewed from the bottom of the mower) to loosen the blade bolt.
- Remove blade bolts, washers, flat washers and blades.
- Place the new blade on the blade holder in the direction of the original blade, and make sure that the two semicircular holes at the center of the blade fit into the semicircular protrusions of the blade holder.
- Replace with new nylon flat gaskets, blade septa, and bolts. Note: Make sure to install the parts back in the reverse order of disassembly during assembly (see Figure 13).
- Use a torque wrench (please bring your own) to tighten the blade bolts clockwise to ensure that the bolts are in place. The recommended torque of the blade bolt is: 40N.M .

⚠ WARNING

Ensure blade is properly seated and the blade nut is tightened to the torque specifications above. Failure to properly attach the blade could cause it to come loose and result in possible serious personal injury.

Repeat with second blade, if needed.

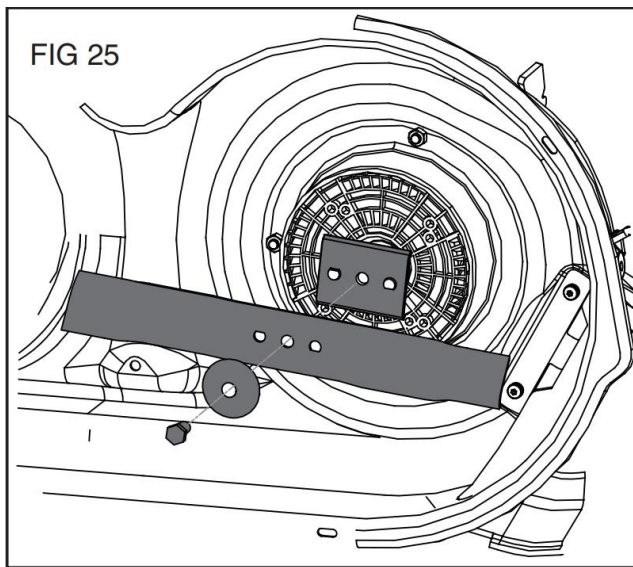
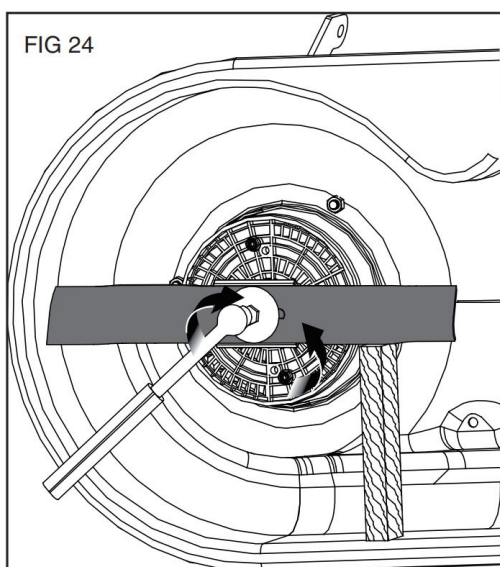

Tire maintenance

This mower is equipped with tubeless tires of the size and type listed below:

	Front	Rear
Size	13"	16"

Tire Air Pressure:

Check the air pressure in all tires before use. Improper air pressure will affect handling, steering response, traction, tire life, level cutting, and operator comfort. Be sure tires are inflated to the pressure shown below.

NOTE: Tire pressure should only be measured or adjusted when tires are cold.

Recommended Pressure: 20 psi (137.9 kpa)

⚠ WARNING

Check the tire pressure carefully while inflating. Too much air in the tire could cause the tire to burst, causing serious personal injury.

⚠ WARNING

Maintaining correct air pressure in the tires is very important. Too little pressure could allow the tire to rotate off the wheel rim. Too much pressure could cause the tire to burst. Failure to maintain correct air pressure in the tires could cause problems with mower operation and stability, causing serious personal injury.

TIRE REPAIR

If a leak or flat tire occurs due to a puncture, the tire may be repaired using a plug type patch. If the damage is from a cut, or if the puncture cannot be repaired using a plug, the tire should be replaced.

REPLACING TIRES

When tires are worn, the traction of the mower will be decreased, which increases the chance of having an accident. Tires should be replaced when the depth on the tread is 0.16 in. (4 mm or less, or any time there is damage to the tire. Always use identical replacement tires. Using improper tires on the mower could cause loss of control, which could cause serious personal injury. Have tires replaced by an authorized service center or a qualified tire repair station.

Adjusting the brakes (See Fig.26)

Being able to stop the mower properly is critical to mowing safety. If you've noticed your mower traveling farther before stopping when you depress the brake pedal, the brakes may need adjusting.

To test:

- Park the mower on a level surface and set the parking brake.
- Place the direction control switch in neutral (N).
- Stand behind the mower and try to push it forward. If the rear tires turn, the brakes need to be tightened.

To tighten:

- Locate the brake adjustment nuts on the interior side of each of the rear wheels.
- Turn each adjustment nut 1/4 turn clockwise, then try again to push the mower.
- Continue rotating each nut 1/4 turn and testing until the mower can no longer be moved by pushing.

After final adjustment, test the brakes by driving the mower at normal speed on flat ground to be sure the mower stops quickly when the brake pedal is depressed.

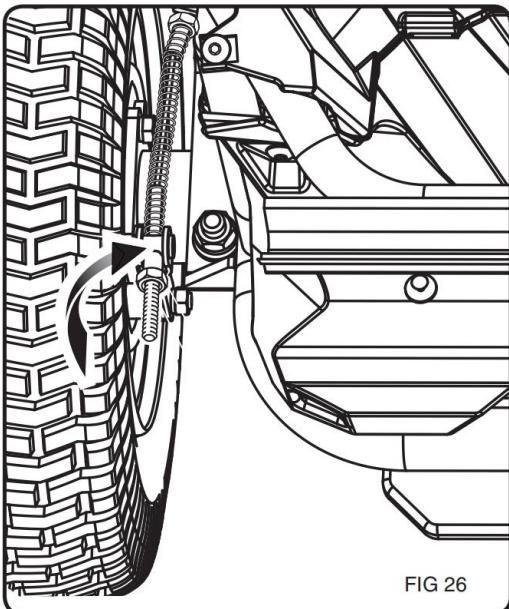

REPLACING THE BATTERIES (See Figure 27-29)

NOTE: Model D21RM530 riding mower only uses Reese battery 12V 50Ah.

This mower operates on four 12-volt batteries connected in a series. If replacing one or more of the batteries, always replace using a battery of the same type with equal voltage and capacity.

WARNING

Use only identical lead acid batteries when replacing. Never mix different makes and sizes of batteries in the series. Doing so will eventually cause damage to the batteries and may also damage the mower.

WARNING

Do not open or mutilate the batteries. Released electrolyte is corrosive and may cause damage to the eyes or skin. It may be toxic if swallowed.

Do not dispose of the batteries in a fire. The batteries could explode. Check with local codes for possible special disposal instructions.

When batteries are not in use, keep away from other metal objects like paper clips, coins, keys, nails, screws, or other small metal objects that can make a connection from one terminal to another. Shorting the battery terminals together may cause burns or a fire.

Exercise care in handling batteries in order not to short the battery with conducting materials such as rings, bracelets, and keys. The battery or conductor may over-heat and cause serious burns.

- Park the riding mower on a level ground, set the parking brake, turn off the power, and take out the key.
- Lift the seat forward and pull out the seat sensing cable from the middle joint.
- Remove the 6 screws fixing the upper cover, pull out the connection cable between the charging socket and the riding mower, and take out the upper cover.
- Disconnect all the connecting wires between the battery and the riding mower from the joints.
- Remove the battery bead and screw of the battery waterproof cover, unfasten the clamps that fix the wiring harness, and take out the battery waterproof cover.
- Remove the series wires from the battery terminals.

Note: Do not short-circuit between the terminals.

- Pull out the battery from back to front until the battery to be replaced is taken out. The battery is heavy, please handle with care to prevent the battery from being damaged by collision. It is recommended to lift the battery at the same time, support the bottom of the battery with your other hand.
- Put in the new battery from the front to the back, and place it according to the position when it was taken out; Be careful of short-circuiting the battery.
- In the reverse order of disassembly, install the battery waterproof cover, battery fixing plate and screw in sequence. Connect the battery power cord to the plug of the riding mower, and then fix it with a wire clip.
- Connect the cable between the charging socket and the riding mower, the round hole of the cover plate of the upper cover penetrates upwards.
- Fix the rear cover on the frame with screws and connect the upper joint of the seat sensor cable to the lower connector connection.
- Reset the seat. The operator sits on the seat, inserts the key to turn on the power switch, and observes check whether the electricity meter is displayed normally.

NOTE: Be sure to observe the safety warning signs provided by the battery. According to when Local regulations to dispose of used batteries.

⚠ WARNING

Under extreme usage or temperature conditions, battery leakage may occur. If liquid comes in contact with your skin, wash immediately with soap and water. If liquid gets into your eyes, flush them with clean water for at least 10 minutes, then seek immediate medical attention. Following this rule will reduce the risk of serious personal injury.

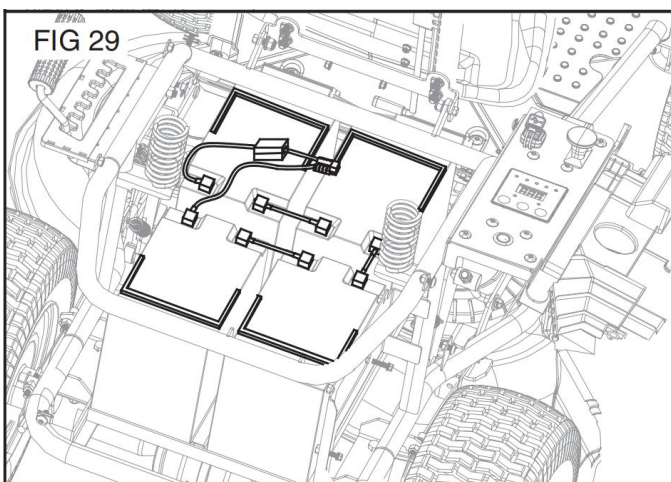
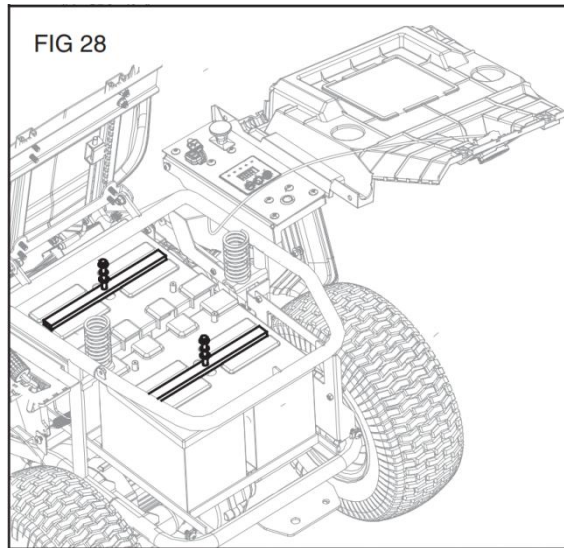
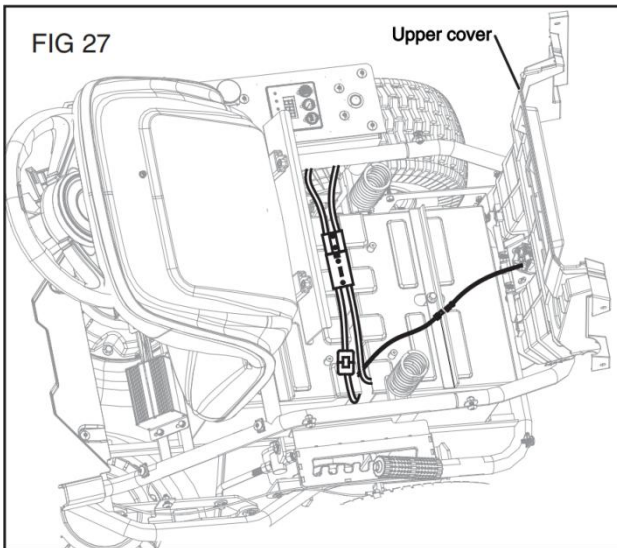

8. STORING THE PRODUCT

The following steps should be taken before storing the mower for the season.

- Remove any buildup of grass and leaves on or around the motor cover. Wipe the mower clean with a dry cloth. Do not spray with a garden hose to clean.
- Plug the mower up to charge for the entire time of storage.

NOTE: If it is not possible to leave the mower charger connected during storage, charge the batteries at least once a month during storage.

- Store mower in a clean, dry place that is inaccessible to children. Do not store near any appliance that operates with flame such as a gas water heater, clothes dryer, or furnace.

NOTE: Do not leave the key in the mower during storage.

- If the mower must be stored outside, make sure it is covered completely to protect it from the elements.
- Keep away from corrosive agents such as garden chemicals and deicing salts.

PREPARING FOR USE AFTER STORAGE

The following steps should be taken before using the mower after it has been stored:

- Review maintenance chart.
- Fully charge the batteries.
- Check tire pressure and inflate as needed.
- Briefly drive the mower and check all systems and components to ensure they are functioning correctly.

BATTERY REMOVAL AND PREPARATION FOR RECYCLING

To preserve natural resources, please recycle or dispose of batteries properly.

This product uses lead acid batteries. Local regulations may prohibit disposal in ordinary trash. Handle the battery. For battery recycling and disposal program information, please consult local waste Authority.

WARNING

Upon removal, cover the battery's terminals with heavy duty adhesive tape. Do not attempt to destroy or disassemble battery or remove any of its components. Lead acid batteries must be recycled or disposed of properly. Also, never touch both terminals with metal objects and/or body parts as short circuit may result. Keep away from children. Failure to comply with these warnings could result in fire and/or serious injury.

9. MAINTENANCE SCHEDULE

Inspect item	Inspect before each use	Every 24 Hours	Every 50 Hours	Every 100 Hours	Before Storage
Check Brake Operation	●				
Check Tire Pressure	●				
Check Safety Interlock System	●				
Check for Loose Fasteners	●				●
Clean debris from Mower	●		●		●
Check/Replace Mower Blades		●	●		
Adding Oil to Transaxle				●	
Clean Battery Terminals			●		
Lubricate mower pivot points, front axle pivot and axle spindles, front axle wheel bushings, and deck pivot points.		●			

NOTE: “●” indicates the items to be checked within a period.

- Maintenance should be performed more frequently when mower is used in dusty areas.
- When mower has exceeded the maximum figures specified in the table, maintenance should still be cycled according to the intervals of time or hours stated herein.
- If you are unsure how to perform any of the maintenance items listed above, take the mower to an authorized service center for assistance.

10. TROUBLESHOOTING

IF THESE SOLUTIONS DO NOT SOLVE THE PROBLEM CONTACT YOUR AUTHORIZED SERVICE DEALER.

PROBLEM	POSSIBLE CAUSE	SOLUTION
The key is inserted but the machine does not start.	<ol style="list-style-type: none"> 1.The battery is too low. 2.The charger is not unplugged. 3.The key is not turned to the "on" position. 4.Poor connection of battery circuit. 	<ol style="list-style-type: none"> 1.Charge the battery. 2.Unplug the charger. 3.Turn the key to the "on" position. 4.Check and clean the wiring connection.
The riding mower does not work when the forward pedal is depressed.	<ol style="list-style-type: none"> 1.Parking brake activated. 2.The machine is low on battery. 3.The machine is malfunctioning. 	<ol style="list-style-type: none"> 1.Cancel the parking brake. 2.Charge the machine. 3.Contact authorized after-sales service center for testing.
The riding mower cuts the grass unevenly.	<ol style="list-style-type: none"> 1.Uneven tire air pressure. 2.The left and right height difference of the cutter head is too large. 3.Worn or damaged blades. 4.Weeds piled up in the cutter head. 5.Mowing too fast. 	<ol style="list-style-type: none"> 1.Check and adjust the air pressure of the four tires. 2.Adjust the left and right height of the cutter head. 3.Replace the blade. 4.Clean the weeds from the cutter head. 5.Reduce mowing speed.
The riding mower vibrates severely.	<ol style="list-style-type: none"> 1.The riding mower vibrates severely. 2.The motor shaft of the blade is bent. 	<ol style="list-style-type: none"> 1.Replace the blade. 2.Stop the machine and remove the start key to check for damage. If damaged, contact an authorized after-sales service center for repair.
The mowing effect is not good.	<ol style="list-style-type: none"> 1.Side exhaust ducts or openings are blocked. 2.Grass is wet. 3.Mowing too fast. 4.The grass grows too high. 	<ol style="list-style-type: none"> 1.Clean side exhaust ducts or openings. 2.Wait until the grass is dry. 3.Reduce mowing speed. 4.Re-mowing the area where the grass is too high.
The blade stops working while mowing.	<ol style="list-style-type: none"> 1.The position of the cutter head is too low. 2.The battery is too low. 	<ol style="list-style-type: none"> 1.Increase the height of the cutter head. 2.Charge the battery.
The blade does not start.	<ol style="list-style-type: none"> 1.The battery is too low. 2.The motor switch of the blade is not turned on. 3.Operator is not fully seated. 4.There are debris in the cutter head blocking the blade from working. 	<ol style="list-style-type: none"> 1.Charge the battery. 2.Turn on the blade motor switch 3.The operator is fully seated in the seat. 4.Clean the bottom of the cutter head.

<p>The blade does not work when retreating to mowing.</p>	<p>1.RMO button is not pressed. 2.The motor switch of the blade is not turned on.</p>	<p>1.Press the RMO button to enter the backward mowing mode. 2.Turn on the blade motor switch.</p>
<p>riding mower cannot reach full speed.</p>	<p>1.The battery is too low.</p>	<p>1.Charge the battery.</p>
<p>After the operator is not activate the parking brake and leave the operating seat, the blade continued to work.</p>	<p>1.The security system is not working properly.</p>	<p>1.Send the riding mower to the after-sales center for inspection and repair.</p>
<p>The headlight does not turn on when the light button is pressed.</p>	<p>1.Headlamp is damaged. 2.Wiring is damaged.</p>	<p>1.Replace the headlight. 2.Check wiring, contact an authorized after-sales service center.</p>
<p>The battery cannot be charged.</p>	<p>1.Battery is damaged. 2.The charging cradle's wiring failure. 3.The charger is damaged.</p>	<p>1.To replace the battery. 2.Send the riding mower to the after-sales center for inspection and repair. 3.Replace the charge.</p>

11. DECLARATION OF CONFORMITY



BUILDER SAS

32 rue Aristide Bergès - Z.I. du Casque - 31270 Cugnaux - France

declares that:

Product: Cordless rider

Trade mark: FEIDER

Model:FRE7548V

Serial number: 20221013767-20221013782

Is in conformity with the essential requirements and other relevant provisions of the applicable European Directives, based on the application of European harmonized standards. Any unauthorized modification of the apparatus voids this declaration.

European Directives (including, if applicable, their amendments up to the date of signature);

Rohs directive 2011/65/EU + (EU) 2015/863

Directive Machine 2006/42/EC

Directive EMC 2014/30/UE

Noise Emission Directive : Annex V Directive 2000/14/EC amended by 2005/88/EC

Measured sound power level 99.4 dB(A)

Guaranteed sound power level 100 dB(A)

European harmonized standards (including, if applicable, their amendments up to the date of signature);

EN ISO12100: 2010

EN62841-1: 2015

EN ISO5395-1: 2013+A1

EN ISO5395-3: 2013+A1+A2

EN IEC55014-1: 2021

EN IEC55014-2: 2021

EN IEC61000-3-2: 2019+A1

EN 61000-3-3: 2013+A1

The notified body: No. 0197

TUV Rheinland LGA Products GmbH - Tillystraße 2 - 90431 Nürnberg – Germany

Cugnaux, 15/09/2022

Philippe MARIE / PDG

Responsible of the technical file: Mr Olivier Patriarca

12. WARRANTY



WARRANTY

The manufacturer guarantees the product against defects in material and workmanship for a period of 2 years from the date of the original purchase. The warranty only applies if the product is for household use. The warranty does not cover breakdowns due to normal wear and tear.

The manufacturer agrees to replace parts identified as defective by the designated distributor. The manufacturer does not accept responsibility for the replacement of the machine, in whole or in part, and/or ensuing damage.

The warranty does not cover breakdowns due to:

- insufficient maintenance.
- abnormal assembly, adjustment or operations of the product.
- parts subject to normal wear and tear.

The warranty does not extend to:

- shipping and packaging costs.
- using the tool for a purpose other than that for which it was designed.
- the use and maintenance of the machine done in a manner not described in the user manual.

Due to our policy of continuous product improvement, we reserve the right to alter or change specifications without notice. Consequently, the product may be different from the information contained therein, but a modification will be undertaken without notice if it is recognized as an improvement of the preceding characteristic.

READ THE MANUAL CAREFULLY BEFORE USING THE MACHINE.

When ordering spare parts, please indicate the part number or code, you can find this in the spare parts list in this manual. Keep the purchase receipt; without it, the warranty is invalid. To help you with your product, we invite you to contact us by phone or via our website:

- **+33 (0)9.70.75.30.30**
- **<https://services.swap-europe.com/contact>**

You must create a "ticket" via the web platform.

- Register or create your account.
- Indicate the reference of the tool.
- Choose the subject of your request.
- Describe your problem.
- Attach these files: invoice or sales receipt, photo of the identification plate (serial number), photo of the part you need (for example: pins on the transformer plug which are broken).



13. PRODUCT FAILURE

WHAT TO DO IF MY MACHINE BREAKS DOWN?

If you bought your product in a store:

a) Empty the fuel tank if your product has one.

b) Make sure that your machine is complete with all accessories supplied, and clean! If this is not the case, the repairer will refuse the machine.

Go to the store with the complete machine and with the receipt or invoice.

If you bought your product on a website:

a) Empty the fuel tank if your product has one.

b) Make sure that your machine is complete with all accessories supplied, and clean! If this is not the case, the repairer will refuse the machine.

c) Create a SWAP-Europe service ticket on the site: <https://services.swap-europe.com> When making the request on SWAP-Europe, you must attach the invoice and the photo of the nameplate (serial number).

d) Contact the repair station to make sure it is available before dropping of the machine.

Go to the repair station with the complete machine packed, accompanied by the purchase invoice and the station support sheet downloadable after the service request is completed on the SWAP-Europe site

For machines with engine failure from manufacturers BRIGGS & STRATTON, HONDA and RATO, please refer to the following instructions.

Repairs will be done by approved engine manufacturers of these manufacturers, see their site:

- <http://www.briggsandstratton.com/eu/fr>
- <http://www.honda-engines-eu.com/fr/service-network-page;jsessionid=5EE8456CF39CD572AA2AEEDFD290CDAE>
- <https://www.rato-europe.com/it/service-network>

Please keep your original packaging to allow for after-sales service returns or pack your machine with a similar cardboard box of the same dimensions.

For any question concerning our after-sales service you can make a request on our website <https://services.swap-europe.com>

Our hotline remains available at +33 (9) 70 75 30 30.



14. WARRANTY EXCLUSIONS

THE WARRANTY DOES NOT COVER:

- Start-up and setting up of the product.
- Damage resulting from normal wear and tear of the product.
- Damage resulting from improper use of the product.
- Damage resulting from assembly or start-up not in accordance with the user manual.
- Breakdowns related to carburetion beyond 90 days and fouling of carburetors.
- Periodic and standard maintenance events.
- Actions of modification and dismantling that directly void the warranty.
- Products whose original authentication marking (brand, serial number) has been degraded, altered or withdrawn.
- Replacement of consumables.
- The use of non-original parts.
- Breakage of parts following impacts or projections.
- Accessories breakdowns.
- Defects and their consequences linked to any external cause.
- Loss of components and loss due to insufficient screwing.
- Cutting components and any damage related to the loosening of parts.
- Overload or overheating.
- Poor power supply quality: faulty voltage, voltage error, etc.
- Damages resulting from the deprivation of enjoyment of the product during the time necessary for repairs and more generally the costs related to the immobilization of the product.
- The costs of a second opinion established by a third party following an estimate by a SWAP-Europe repair station
- The use of a product which would show a defect or a breakage which was not the subject of an immediate report and/or repair with the services of SWAP-Europe.
- Deterioration linked to transport and storage*.
- Launchers beyond 90 days.
- Oil, petrol, grease.
- Damages related to the use of non-compliant fuels or lubricants.

* In accordance with transport legislation, damage related to transport must be declared to carriers within 48 hours maximum after observation by registered letter with acknowledgement of receipt.

This document is a supplement to your notice, a non-exhaustive list.

Attention: all orders must be checked in the presence of the delivery person. In case of refusal by the delivery person, it you must simply refuse the delivery and notify your refusal.

Reminder: the reserves do not exclude the notification by registered letter with acknowledgement within 72 hours.

Information:

Thermal devices must be wintered each season (service available on the SWAP-Europe site). Batteries must be charged before being stored.

FEIDER

MACHINES



BUILDER SAS

32 rue Aristide Bergès - Z.I. du Casque - 31270 Cugnaux - France

MADE IN PRC